



CULTIVATE
Perry County

The Perry County Chamber of Commerce and The Perry County Economic Development Authority would like to thank our Township Officials and employees for their commitment to Perry County and our citizens!

For information about how the Chamber and EDA can benefit your township, email or call.

Perry Business & Tourism Center
9 West Main Street
New Bloomfield, PA 17068

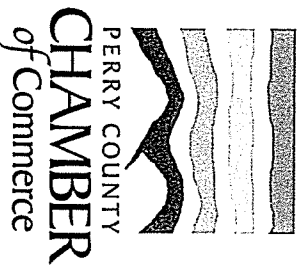

717.582.4523

www.perrycountychamber.org
pccc@perrycountychamber.org



717.582.0367

www.perrycountyeda.com
info@perrycountyeda.com

**Perry County Association
of
Township Officials**



**111TH
ANNUAL**

CONVENTION

September 14, 2024



Perry County Fairgrounds
Newport, Pennsylvania



Photo on front cover: Little Buffalo State Park / Holman Lake

NOTES

PROGRAM

8:00 a.m. to 9:00 a.m.
VISIT WITH EXHIBITORS
Continental Breakfast

9:00 a.m. to 10:00 a.m.

- *WORKSHOPS
- ◆ SECRETARIES
Holly Fishel - PSATS
- ◆ SUPERVISORS
Adam Leister - MCM Consulting Group Inc.
- ◆ AUDITORS
Teena Curnow - SEK
- ◆ TAX COLLECTORS
Connie Moore - PSATC
- ◆ ZONING & PLANNING COMMISSION
Andrew Bomberger & Jason Finnerty
Tri-County Planning Commission
- ◆ EMA - Adam Leister - MCM Consulting Group Inc.

10:00 a.m. to 10:15 a.m. BREAK – VISIT WITH EXHIBITORS

10:15 a.m. to 11:00 a.m. GENERAL WORKSHOP SESSION

- ◆ Perry Co Planning Comm - Jason Finnerty
- ◆ Perry Co EMA - Adam Leister
- MCM Consulting Group, Inc.

TAX COLLECTORS - Continue with
Connie Moore - PSATC

11:00 a.m. to 11:15 a.m. BREAK – VISIT WITH EXHIBITORS

11:15 a.m. to 12:00 p.m. GENERAL SESSION

Invocation.....President John Hess, Jr.
Salute to our Flag.....Entire Convention
Convene the Meeting.....Pres. John Hess, Jr.
RemarksSenator Rothman
RemarksRepresentative Stambaugh
RemarksPerry Co. Commissioners
Legislative Wrap Up.....Dave Sanko, PSATS

12:00 p.m. to 1:00 p.m. LUNCH - Pomona Grange

1:00 p.m. Approval of Secretary's 2023 Minutes and
2024 Treasurer's Report
Random Drawings to Award Door Prizes

ADJOURNMENT

**(All workshops are open to anyone interested, no matter what your title or position)*

OFFICERS 2023-2024

PRESIDENT John Hess, Jr.
 Juniata Township

1ST VICE PRESIDENT Keith Finton
 Buffalo Township

2ND VICE PRESIDENT Zachary Kuhn
 Jackson Township

SECRETARY/TREASURER Jill Hoover
 Oliver Township

ASSISTANT SECRETARY Diana McPherson
 Centre Township

PAST PRESIDENT Art Lindsay
 Buffalo Township

MEMBER AT LARGE Jim W. Fuller, Sr.
 Tuscarora Township

SENATORS, REPRESENTATIVES & CONGRESSMEN:

Representative Perry Stambaugh
 18 W Main Street, P.O. Box 9
 New Bloomfield, PA 17068
 Phone: (717) 582-8119

Senator Greg Rothman
 25 E McClure St, P.O. Box 236
 New Bloomfield, PA 17068
 Phone: (717) 582-2454

Congressman John Joyce
 Chambersburg District Office
 100 Lincoln Way East, Suite B
 Chambersburg, PA 17201
 Phone: (717) 753-6344

Perry County Commissioners
 Brenda L. Watson
 Frank Campbell
 Bill Lyons
 Veterans Memorial Building
 25 W Main Street
 New Bloomfield, PA 17068
 Phone: (717) 582-2131

INDEX OF ADVERTISERS

Building Inspection Underwriters, Inc. 68

Capital Tax Collection Bureau 60

Chemung Supply Corp. 59

Cupp Insurance Agency, Inc. 65

Deibler, Straub and Troutman 59

E.M. Kutz, Inc. 55

Frederick, Seibert & Associates 67

H.A. Thomson Risk Management Services 63

Jay Fulkroad and Sons, Inc. 66

Lancaster Truck Bodies 56

PA One Call 54

Pennian Bank 64

Perry County Chamber of Commerce bc

PLGIT 55

PSATS Trustees Insurance Fund 52

Share Corporation 63

Smith Elliott Kearns & Company, LLC 57

Stahl Sheaffer Engineering 61

Stephenson Equipment, Inc. 58

The Bank of Landisburg 62

The EADS Group 69

Trapp Health Insurance and Medicare Advisors 53

US Municipal 66

Section 2.

The Executive Board shall have full charge of the affairs of the Association between Conventions. It shall meet annually prior to the Annual Convention at a time and place selected by the President. At that time, it shall confirm or amend the report of the Treasurer, certify the date of the forthcoming Convention, assist, and cooperate with the Secretary in preparation of a suitable program, and transact any other business that may come to its attention. The President may call a special meeting of the Executive Board as occasions for its service may arise.

Section 3.

The President shall appoint the following standing committees: a Resolution Committee, a Nomination Committee, and Special Committee for specific purposes as occasion may require.

Section 4.

The Resolution Committee shall annually present proposed resolution for consideration by the Convention.

Section 5.

The Executive Board shall have full voting privileges.

**ARTICLE X
DUES**

The dues requested shall be at the rate of thirty-five (\$35) dollars annually. If the authorized activities of the Association require it, the dues may be fixed at a higher rate after first being approved by a majority vote of the convention. Any Township failing, neglecting, or refusing to pay its Association dues shall be deprived of free access or all Special Privileges of the Association.

**ARTICLE XI
AMENDMENTS**

These By-Laws may be amended at any regular meeting of the Association by submitting proposed amendments in writing sixty (60) days prior to the Convention and by a two-thirds vote of the members present and voting.

**TREASURER'S REPORT
May 1, 2024**

Bank of Landisburg Beginning Balance		\$5,392.31
PLGIT		\$ 673.32
BANK OF LANDISBURG CD		\$2,882.41
(Matures 6-12-25)		<u>\$8,748.04</u>

REVENUES:	TOTAL	\$8,948.04
CONVENTION RECEIPTS		
DUES	\$ 700.00	
MEAL TICKETS	1,680.00	
ADS/EXHIBITS	1,780.00	
DONATIONS FOR BREAKFAST	80.00	

INTEREST		
PLGIT ACCOUNT INTEREST	35.11	
BANK OF LANDISBURG CD INTEREST	71.34	

TOTAL RECEIPTS		\$4,346.45
TOTAL FUNDS AVAILABLE		\$13,294.49

EXPENSES		
ADMINISTRATIVE		
EXECUTIVE BOARD EXPENSES	\$793.93	
OFFICE SUPPLIES, POSTAGE	105.93	
PSATS DUES	25.00	

CONVENTION EXPENSES		
RENTAL OF FACILITY & EQUIPMENT	\$ 874.80	
MEALS	1,890.00	
PRINTING	873.00	
DOOR PRIZES	0.00	
BREAKFAST BUFFET	275.14	
TOTAL EXPENSES	<u>275.14</u>	\$(4,837.80)

BALANCE		\$8,456.69
BANK OF LANDISBURG CHECKING		\$4,794.51
BANK OF LANDISBURG CD		\$2,953.75
PLGIT ACCOUNT		\$ 708.43
TOTAL BANK OF LANDISBURG AND PLGIT		\$8,456.69

MINUTES OF THE 2023 CONVENTION

The 110th Annual Convention of the Perry County Association of Township Officials, (PCATO) was held on September 9, 2023, at the Perry County Fairgrounds, Newport with an attendance of 135 including the following executive board members present:

John Hess, Jr.,-President
Zachary Kuhn-2nd Vice President
Jill Hoover-Secretary/Treasurer

Keith Finton-1st Vice President
Art Lindsay-Past President
Diana McPherson-Asst. Secretary Jim Fuller-Member at Large

Following the welcome and invocation by President - John Hess, Jr., the general session of the Convention body was convened to order with the Pledge of Allegiance to the United States Flag. Present John Hess, Jr. commented that the convention was being recorded for secretarial purposes.

Sara Keller from Senator Greg Rothman's office was the first to speak. Hello, I am Sara Keller on behalf of Senator Rothman. He regrets that he could not be here in person today, but I'm delighted to be with you as usual every year. I do want to point out that I have literature back there and I have a lot of copies of grants for municipal leaders. I will be here until noon, feel free to pick them up. I would like them to be a resource for you. I also have some specifically for first responders as well; so, feel free to pick up one of those and for the senator, he would like to pass on some legislative updates, I think Holly and Dave have touched on a couple of these already. One is the Senate Bill giving expanded the flexibility for county and municipal bridges, by allowing monies allocated to Act 89 of 2013 and Act 44 of 2007 to be used on municipal owned bridges, the bill is awaiting Senate Transportation Committee, and as it currently stands, those funds can only be used on county owned bridges. Going on to Senate Bill 666, which was introduced by Senator Rothman, which is EV Electric Vehicle fee, it's going to streamline the process that allows electric vehicles owners to pay their yearly fees; while also insuring they distribute their fair share towards road and bridges that we all use. The Senator wanted to convey he recognizes the necessary role that roads and bridges play in your working districts, and he is committed to a joint conversation between PennDOT, Representative Stambaugh and the Commissioners to addressing those issues swiftly. The Senator also introduced a resolution to study how repairs to roads and bridges can be done more quickly and more efficiently to reduce the cost and time necessary to provide good effective service. Short and sweet I will be in the back, if you need anything, have a lovely day.

Representative Perry Stambaugh - Thank you and thanks for all of you do for Perry County and for your local municipalities it's very much appreciated, and I know you are doing it because you want to give back to your community and thank you for your service. One of the things that came out of the Area Agency of Aging hearing that were held at different senior centers, was the concern from seniors that there were not handicapped accesses to their polling places; now we checked, and everyone has handicapped access at their polling places, but in some cases it's not very well marked. We already have prying eyes on our election process right now, so please make sure that if you want people to get into your polling place, that you put some signage out that shows people where those handicapped entrances and exits are, so that they know. I was surprised at how many seniors at these events said their polling places are not handicapped accessible, when it is. So, it's something to look

Section 2.

The Secretary/Treasurer and Assistant Secretary shall keep a correct record of minutes of all meetings including those of the Executive Board, shall maintain a complete roll of the membership, shall to all correspondence, and shall perform all other duties pertaining to a secretaryship or that the President may require of same. The Secretary shall be the custodian of all Association property and shall turn the same over to his or her successor in office.

Section 3.

The Secretary/Treasurer shall be charged with the responsibility in the preparation of a suitable program for the forthcoming convention, shall be given full assistance and cooperation of the Executive Board and / or others that may be called upon and shall be compensated at a rate of five hundred (\$500) dollars per year.

Section 4.

The Secretary/Treasurer of the Association shall receive and collect all monies due to the Association, shall deposit funds in a bank in the name of the Association, shall pay out same on approved orders.

ARTICLE VIII

SUCCESSION IN OFFICE

Section 1.

In case the President elect should be for any reason be unable to perform the duties of his office, then the first Vice-President, and after him the second Vice-President, shall serve until such time as the President is again able to perform the duties.

Section 2.

In case the Secretary/Treasurer becomes incapacitated to perform the duties of the office, or to direct them to be done, then the President with the approval of the Executive Board shall appoint someone with full authority to serve until such time as the Secretary/Treasurer is again able to perform the duties.

Section 3.

The President shall not serve more than two (2) years consecutively.

ARTICLE IX

EXECUTIVE BOARD AND COMMITTEES

Section 1.

The Executive Board shall consist of six members: the President, the first Vice-President, the second Vice-President, the Secretary/ Treasurer, and the immediate Past-President, and the Member at Large.

**ARTICLE V
MEETINGS**

Section 1. There shall be an Annual Convention of the Association held during the year in Pennsylvania at a suitable place and time selected by the Executive Board.

Section 2. The President may call a special meeting of the Association or any members of any branch thereof when authorized to do so by the Executive Board.

**ARTICLE VI
OFFICERS**

Section 1. The officers of the Association shall be a President, a first Vice-President, a second Vice-President, a Secretary/Treasurer- (shall be the same person), and an Assistant Secretary.

Section 2. The term of service of the officer shall be for two (2) consecutive years from the close of an Annual Convention until the close of the second Annual Convention.

Section 3. The officers of the Association shall be elected near the close of the Convention. They shall assume the duties of their offices immediately after the close of that session and continue to serve until their successors are elected.

Section 4. The above-named officers and the immediate, Past-President and Member-at-Large shall be known as the Executive Board.

**ARTICLE VII
DUTIES OF OFFICERS**

Section 1. The President shall call all regular meetings, shall preside at all meetings, shall appoint all committees and be ex-officio member of each, shall perform all other duties generally incumbent on a President, and shall be compensated at the rate of seventy-five (\$75) dollars per year.

at as you get your polling place ready for election time. I'm on the house transportation committee, eventually the state of Pennsylvania is going to have to look at doing a full comprehensive overhaul on transportation policy. However it takes shape, I don't think anyone knows at this point, but one of the things I am definitely going to keep my eye on, is that whatever is done on state level also helps out, townships and boroughs with making sure you get enough money for your rural roads and bridges. We already know we have statewide support which is a drop in a hole with county road needs and township road needs, so making sure that liquid fuels tax money is rolling in at a rate that you need it that benefits our municipalities. The PSATS person who talked about facetious requests on right to know law, we have a very facetious companies that operates in Perry County, I call them Brightspeed, the old CenturyLink company, it's probably the number one complaint I hear by constituents, so contact our office about a problem, such as a telephone pole laying on our tree or a telephone pole that snapped off for five years and laying on the ground; then the cable crew came out and patched the line together and the line is still laying on the ground. We've been pretty successful at getting Brightspeed to send out actual real line crew to repair the lines and get the lines up. So, if you have this issue in your township, please let my office know and we will work on it, we have been having pretty good success in getting them fixed when we know about them. Finally, if you have any issues or complaints, or ideas, suggestions, whatever, please contact our office, so please reach out to our staff. Thank you.

Perry County Commissioners Brian Allen and Larry Reisinger were present and addressed the Convention Body.

Commissioner Brian Allen - I am sure you are getting a lot of questions on the assessment. Larry will speak about that. We received a proposal which has taken a long time to move forward with an infrastructure grant. An infrastructure grant is really the best tool the township and boroughs will have to complete some long rather cost prohibitive projects you may have. It may be a road that has gotten bad, like Meadow Grove Road, or a culvert or a bridge, tiles under a certain road really any type of infrastructure. So, putting this grant together, we took 2 million dollars of the ARPA money and what it does is essentially turns 2 million dollars into 13, if you stretch it out. If the township doesn't have an engineer, many of you do, but if you don't, it's not going to be a problem to get these projects figured out, there will be a team that can come in and assist the township in any way you folks deem necessary. We just got the proposal, and we are forwarding to our solicitor and we expect to be voting on that here ins 2 to 3 weeks. Every township should be receiving a letter explaining it and the contact information, so you can take advantage of it or they can answer questions certainly better than me. Thank you.

Commissioner Larry Reisinger was next to speak. Good morning as Brian said, if you read the local newspaper for the last month, you are well aware that Perry County is going through a reassessment and there has been a lot of confusion that Perry County did not advertise that. So, we heard you say that, so on September 20th, Wednesday at the Family Life Center at 7 o'clock there is going to be an open meeting on the reassessment. Now the first part of that meeting is going to be an educational session presented by VISION, the name of the company we hired to do the reassessment. There has been a lot of miss information in the newspaper and passed around on social media, so we want them to do an education session on exactly what a reassessment is and does. Then it will be open to questions and answers, that for what we don't exactly have down yet. So, September 20th, 7 o'clock, Family Life

Center, my gut feeling is that when they are done with their educational part of their presentation that 50% of the questions, we, you, the populous of Perry County have, are going to be answered. If I can give you an example, I have been a commissioner now for 7 months, I took Gary Eby's place, who unfortunately had health issues. Prior to that, all my life I worked at auctions that sold real estate; let me give you an example, if you look out there, there is a farm, we have a sale there Saturday and that farm was assessed at \$400,000, we had the sale on Saturday and that farm raised a million dollars; all my life I naively assumed that it will now go on the tax roll at a million dollars. Not true, that's illegal, that's called selective reassessment. So even though assessment is supposed to reflect current market value, even though that brought a million dollars, it is staying on the tax roll at \$400,000. To me that is not fair. It is not the reassessment it is the millage rate that determines what our taxes are going to be. So, you're all invited September 20th and we will learn a lot and I will be around to answer what questions I can. Thank you, enjoy the rest of your day.

Marty Roberts of the Perry County Economic Development Authority, (PCEDA), addressed the Convention Body to explain what the PCEDA does. We have a volunteer board, and our job is to help grow the economy in Perry County. We currently have 120 thousand acres of farmland in the county and about a thousand acres of public land. And if you have a farm many of you have yours in a clean and green tax designation which is wonderful. But as townships and county mandates continue to rise and as millage grows, we have to find ways to strength the economy without changing Perry County, without doing harm and certainly we are not going to lose access to the Appalachian Trail, our rivers and our state park. So, our job is to work with existing businesses to help them strengthen their business and attract new businesses. Our primary project right now, if you haven't heard of it before, is that the 9 boroughs in the county have been designated as a Regional Named Street Program. We are helping businesses in the boroughs to reinvest dollars into their towns so that we can attract new visitors and keep those current customers that our businesses have. We also work closely with the four school districts. We lose too many of our great young people when they graduate from high school to move out of the county, so we have done a few things. We sponsored a career fair and had 40 local businesses attend and they had a very high rate of applications that were submitted to them from kids from 10th to 12th grade. We think of that as a victory. We also have a challenge with our high school age kids, to get them involved with Vo-Tech, it's just hard to get in because there are only so many slots and we are trying to make that better. One of our top priorities that we heard is from the nursing homes in our county that they really needed CNS-Certified Nursing Assistants to get jobs in our homes. We are working diligently with community college to try to get that certification done here in the county for our young people, so they don't have to worry about commuting to get them. We're very active in the state regional program called the Engaged Program where Michelle Jones is our Executive Director and Kylee Spidel is our Downtown Coordinator. We meet with local businesses to try and find out how they are doing; what they need; what could be better. The interview keeps us in touch with how our economy is growing, it is amazing. I'm sure you're all aware of this, people are very interested now in local products, local business and that is really helping some of our business in Perry County, which is a great thing and that you all for participating in that. We also have services for our businesses to help them with business plans and financial projections, all for free. You have to make an appointment, and we can help you. So, I just wanted you all to know that we are working diligently for you, and it is an honor to represent the county, and I appreciate the time. We are also sponsoring a Pickle Ball Tournament in Newport, there is men's, women's and mixed doubles, if successful we can continue this from year to year.

PERRY COUNTY ASSOCIATION OF TOWNSHIP OFFICIALS

CONSTITUTION AND BY-LAWS ARTICLE I PREAMBLE

The Perry County Association of Township Officials is organized under the authority of the Second-Class Township Code: and in any case of conflict between this Constitution and By-Laws and the pertinent sections in the Second-Class Code shall prevail.

ARTICLE II NAME

The Association shall be known as the Perry County Association of Township Officials and shall be the official organization of the Second-Class Township Code in Perry County, Pennsylvania.

ARTICLE III PURPOSE

This Association is formed for the purpose of considering and discussing questions and subjects pertaining to the best methods for the improvement of the Township governments, the assessment of property, the collection of taxes, the construction, improvement and maintenance of roads, and the promotion of mutual co-operation among the member townships.

ARTICLE IV MEMBERSHIP

Section 1. The membership shall consist of the Township Supervisors, the Township Secretaries, the Township Treasurers, The Township Auditors, The Township Tax Collectors of Perry County, Pennsylvania.

Section 2. By majority vote of any regular convention, full membership for life may be conferred upon any retired member who has rendered long and valuable service to Township government.

Section 3. Any member is entitled to vote on any question within the Association and any member can be elected to the office of President and Vice-President and can serve as delegate to the State Convention.

“THANK YOU” FOR YOUR SUPPORT & EXHIBITING

BUILDING INSPECTION UNDERWRITERS
CAPITAL TAX COLLECTION BUREAU
CUPP INSURANCE AGENCY, INC.
E.M. KUTZ, INC.
FREDERICK, SEIBERT & ASSOCIATES
H.A. THOMSON RISK MANAGEMENT SERVICES
JAY FULKROAD AND SONS, INC.
LANCASTER TRUCK BODIES
PA ONE CALL SYSTEM
PENNIAN BANK
PERRY COUNTY REPUBLICAN PARTY
PSATS
SHARE CORPORATION
SMITH ELLIOTT & KEARNS & COMPANY
STAHL SHEAFFER ENGINEERING
STEPHENSON EQUIPMENT
THE BANK OF LANDISBURG
THE EADS GROUP
THE PERRY COUNTY CHAMBER OF COMMERCE
THE PERRY COUNTY ECONOMIC DEVELOPMENT AUTHORITY
TRAPP HEALTH INSURANCE ADVISORS
US MUNICIPAL

Jason Finnerty with Perry County Planning Office and Tri-County Regional Planning Commission introduced himself. I wanted to give an update there are 22 municipalities presently participating in PICTURE PERRY and thank you as our partners in this process and we look forward hopefully to having the rest of the eight municipalities in the county come on board and join us in this unified planning effort. With that, my door is always open, feel free to reach out to me if you want me to come and talk to you a little bit more about this particular process, we are encouraged by this initial first year attempting to bring everyone on board. We understand that there are several municipalities that don't have comp plans still, and there are also municipalities that have comp plans that are coming up on their ten (10) years, maybe beyond ten (10) years and will need to be looked at. We want to make this easier and cheaper for you all, we want to include your thoughts and ideas as part of the roles and objectives in this process. The Tri-County Regional Planning Commission website you can access the PICTURE PERRY Comprehensive Plan, you can link it up to your own website if you have one, if it is a plan you participated in. There is a front end to this particular website that enables you to submit projects that can be worked into this comprehensive plan. Thank you.

With no further speakers, the 2022 minutes were approved unanimously on a Jim Fuller/Joel Baker motion.

With no further discussion, the Treasurer's Report was approved unanimously with a Terry Ulrich/Daisy Lightner motion.

By-Law Amendments Resolution was approved with revisions and corrections on a Jim Fuller/Art Lindsay motion.

Correction: Article IV, Section 2, word show, should read who.

Revision: Article VI, Section 1, Secretary/Treasurer – shall be one position.

Revision: Article VI, Section 3, the compensation shall be for Secretary/

Treasurer at \$500 per year.

Revision: Article VI, Section 4 there is no need for this section as it sets compensation for Treasurer.

There was a motion by Art Lindsay/Dale Beaver to accept the revisions to the resolution.

With no further discussion or business, the session broke for lunch.

After lunch, President Hess reconvened the General Session of the Convention Body. A round of applause was given to the Pamona Grange for a delicious ham luncheon.

Winners of the door prizes were drawn randomly from the lunch tickets.

President Hess thanked everyone for coming. With no further business before the Convention body, a motion was made by Ken Bair-Spring to adjourn the meeting second by Duane Dietz-Spring. Motion carried unanimously.

The convention adjourned at approximately 1:30 p.m.

Respectfully submitted,

Jill E. Hoover | Secretary/Treasurer

MENU

HAM

SCALLOPED POTATOES

SWEET POTATOES

CORN

COLE SLAW

APPLESAUCE

DESSERT

WATER

COFFEE



Thank you to the Perry County Pomona Grange
for providing and serving the delicious luncheon.

COURTHOUSE DIRECTORY 582-2131

PROTHONOTARY OFFICE

P.O. Box 325
Fax Number 582-5167
Ingrid Albright 2286
Kim Straub 2241
Zoe Burd 2239
Ashley Kramer 2240
Jen Brubaker 2288
Christine Casner 2285

PUBLIC DEFENDER

Barbara Wevodau 582-8883

PRISON

300 South Carlisle St. New Bloomfield
Fax Number 582-2377
Office Number 582-2262

RECEPTIONIST OFFICE

2251

REGISTER & RECORDER

P.O. Box 223
Fax Number 582-5149
Darlene Zeigler 2236
Tiffany Kreps 2235
Wendy Wellfley 5148

SHERIFFS OFFICE

P.O. Box 6
Fax Number 582-5115
Private Line 582-5123

Sara Fritz 2279

Jenny Campbell 2277

Donald Brown 2201

Derek Bates 2276

Joe Blosser 2219

Bob Brandt 2202

Noah Cline 2283

David Hammar 2280

CONSERVATION DISTRICT

P.O. Box 36 582-8988
April Skethway 582-8988
Lauren Leinbach-Ag Resource 636-0976
Rebecca Radel-Ag Resource 275-5111
Gabe Futhrie-Manager 582-5139
Tara Collier-Resource Spec 636-2282
Bailey Miller-Watershed 562-4566
Kevin Morgan-NRCS 594-3006
Samantha Kapinus-NRCS 594-3004
NRCS 594-3002
Kyle Fake-Resource Spec 594-3006

TAX CLAIM

Kristine Adkins 582-5111
Michelle Thebes 4121
4111

TREASURER

P.O. Box 5101
Fax Number 582-5161
Jan Gibbooney 5101
Michelle Thebes 4111

VETERANS AFFAIRS

P.O. Box 3 582-5131
Fax Number 582-5131
Jim Scott 413

VICTIMS WITNESS

Laura Radabaugh 582-512

VOTER REGISTRATION

P.O. Box 3 582-510
Fax Number 582-516
Sarah Geesaman 411
Deb Shrawder 410

COURTHOUSE DIRECTORY 582-2131

ELEVATORS
Rhinesmith 2284

EMERGENCY MANAGEMENT

Fax Number 582-7320
Private Line 582-5165
Wes Smith 5165
Rich Fultz 5165
911 Center 5100

FISCAL OFFICE

Fax Number 582-5104
Brandi Clendenin 582-5162
Maggie Gouse 4123
4104

FOOD BANK

Mary Ann Brownawell 594-0027

GIS MAPPING

Dave Unger 2281

JUDGES CHAMBERS

P.O. Box 668
Fax Number 582-5166
Cindy Ziegler 2234
Tracy Fife 2232
Veronica Rheam 2233

JURY COMMISSION

Joy Enck 2210

AREA AGENCY ON AGING

PO Box 725
Main Line 582-5128
Fax Number 582-5160
Allie Thebes 106
Allyson Valentine 103
Amanda Brookhart 118
Amy Weibley (Mon & Tues) 101
Janet Hensel 109
Jessica Finkenbinder 105
Lori Rauch 102
Mary Stump 115
Olivia Frymoyer 107
Quinn Howell 104

PLANNING COMMISSION

Jason Finnerty 4114
Direct Line 582-5124

PROBATION OFFICE

P.O. Box 239
Fax Number 582-5190
Private Line 582-5125
Tammy Rohrer 2252
Kay Zellers 5125
Sarah Delp 2254
Janette Medvidovich 2268
Michelle Orris 2226
Lisa Finkenbinder 2301
Brian Weidow 2302
Mike Steadale 2249
Shelby Anderson 2247
Marshal Wilmer 2250
Joseph Reisinger 2278

**PENNSYLVANIA STATE ASSOCIATION
OF TOWNSHIP SUPERVISORS**

LEADERSHIP TEAM

EXECUTIVE DIRECTOR DAVID SANKO
ASSISTANT EXECUTIVE DIRECTOR MICHELLE CARPENTER
COMMUNICATIONS MANAGER BRENDA WILT
EXECUTIVE EDITOR, PA TOWNSHIP NEWS

MEMBER RECOGNITION MANAGER CASEY EISENHART
ASSISTANT EDITOR, PA TOWNSHIP NEWS

DIRECTOR OF DEVELOPMENT JAMES WHEELER
CDL/TEMA/ENVIRONMENT

TRUST DIRECTOR STEPHANIE DOBSON

RESEARCH AND POLICY DIRECTOR HOLLY FISHEL

DIRECTOR OF INFORMATION TECHNOLOGY ANDREW MUMMERT

CONFERENCE & EVENT MANAGER DONNA CENTOFANTI

EDUCATION DIRECTOR & COUNSEL SCOTT COBURN, ESQ.

GOVERNMENT RELATIONS DIRECTOR JOE GERDES

BUFFALO TOWNSHIP

BUILDING LOCATION 22 Cherry Road, Liverpool, PA 17045
 TOWNSHIP ADDRESS 22 Cherry Road, Liverpool, PA 17045
 TELEPHONE 444-3295
 TOWNSHIP MEETING 1st and 3rd Mondays, 7:00 p.m.
 PLANNING COMMISSION MEETING 1st Wednesday, 7:00 p.m.
 POPULATION 1,219
 MILEAGE 29.01
 EMAIL ADDRESS buffalotwp@pa.net
 WEBSITE www.perrybuffalotwp.org

SUPERVISORS

Gary Witmer
 320 Orchard Road, Liverpool, PA 17045 514-0378
 Art Lindsay, Chairman
 598 Cherry Road, Liverpool, PA 17045 439-4179
 Keith Finton
 639 Mountain Road, Liverpool, PA 17045 215-4311

SECRETARY/TREASURER

Nancy Cangioli
 650 Bucks Church Road, Newport, PA 17074 444-2211

TAX COLLECTOR

Christine Lowe
 624 Mountain Road, Liverpool, PA 17045 275-3626

AUDITORS

Allen Finton
 Colleen Leshner

SOLICITOR

Stock & Leader - Dave Jones
 221 W. Philadelphia Street, York, PA 17401 849-4128

ENGINEER

COURTHOUSE DIRECTORY 582-2131

ASSESSMENT OFFICE

P.O. Box 37
 Fax Number 582-5189
 Debra Rayson 4119
 Christine Gustafson 4122
 Katelyn Smith 4121
 Randy Waggoner 4126
 Rachel Gabner 4117
 Darla McNaughton - UPI 4116
 Nicole Kelly 4118

AUDITORS

Nancy Pote 2265
 Kathy Hoover
 Donna McMillen

CHILDREN & YOUTH

P.O. Box 123
 Fax Number 582-2417
 Main Line 582-2076
 Amber Wolfe 3301
 Mackeyla Paulus 3303
 Andrea Bowersox 3305
 Andrew Ryan 3306
 Jehnika Peters 3307
 Kirsten Chronister 3308
 Jacob Eshelman 3309
 Michelle Carlson 3310
 Rachel Gingrich 3311
 Kristie Gantt 3312
 Megan Hopkins 3313
 Sarah Grubb 3314
 Adelaide Johnson 3315
 Carrie Rushing 3316
 Jessica Miller 3317
 Erin Lazelere 3318
 Megan Radel 3319
 Nick Birbeck 3320
 Helen Britcher 3321
 Catriona Mickey 3324
 Robin Gutshall 3326
 Timothy Rush 3327
 Ken Little 3328

COMMISSIONERS OFFICE

P.O. Box 37
 Fax Number 582-5189
 Angela Schlegel 4100
 Shannon Hines 4105
 Frank Campbell 4101
 Brenda Watson 4102
 Bill Lyons 4103

CO-OPERATIVE EXTENSION

P.O. Box 668
 Fax Number 582-5183
 Linda Jones 582-5150
 Erin Comp 582-5150
 Becky Seachrist 582-5150

COURT ADMINISTRATION

P.O. Box 668
 Fax Number 582-5144
 Angela Hockenberry 2291
 Christina Zook 2256

DISTRICT ATTORNEY

P.O. Box 306
 Fax Number 582-5166
 Faith Weaver 2276
 Clay Merris, 2236
 Erin Johnson 2414
 Cheri Appleby 2221
 Tammy Dunsham 2287

DOMESTIC RELATIONS

P.O. Box 2300
 Fax Number 582-5164
 PACSES Line 582-5176
 Diane Jones 2216
 Emily McKeel 2306
 Sheryl Harbold 2276
 Ed Rigg 2276
 Jesse Kinzer 2256
 Hilary Nace 2256
 Joshua Lahr 2276
 Heather Heckert 2206
 Donna Rhoads 2266
 Catrina Gardner 2276
 Brooke Smith 2226

“THANK YOU”

BUFFALO TOWNSHIP (continued)

PLANNING COMMISSION

Timothy Albright
520 Cherry Road, Liverpool, PA 17045 444-7701
Rebecca Smith, Chairman
409 Meadow Grove Road, Newport, PA 17074 567-2345
Jason Vasil
259 Bucks Church Road, Newport, PA 17074 460-4401
Andrew Bucke
Jason Daniels
Dona Rhoads - Alternate

BUILDING PERMITS/CODE ENFORCEMENT

Tony Liddick
1764 Old Trail Road, Liverpool, PA 17045 991-5403

SEWAGE ENFORCEMENT OFFICER

Juniata Sewage Committee
Mifflintown, PA 436-9094

EMERGENCY MANAGEMENT COORDINATOR

Tim Moench
86 Meadow Grove Road, Newport, PA 17074 215-900-0911

SPECIAL APPRECIATION IS EXPRESSED

TO THE FOLLOWING

FOR THEIR GENEROSITY

IN CONTRIBUTING TO

THE CONTINENTAL BREAKFAST BAR:

Building Inspection Underwriters, Inc.

Frederick, Sebert & Associates, Inc.

Trapp Health Insurance & Medical Advisors

AND FOR DONATION OF GIFT CERTIFICATES
AND MERCHANDISE FOR DOOR PRIZES:

PSATS

BLAIN HOTEL

HELLER'S HOME & HARDWARE

NEWPORT BEVERAGE

C.A. HESS GARAGE

GIANT FOODS

WEIS FOODS

SHARE CORPORATION

KEYSTONE COLLECTION GROUP

CARROLL TOWNSHIP

BUILDING LOCATION 50 Rambo Hill Road
 TOWNSHIP ADDRESS 50 Rambo Hill RD., Shermans Dale, PA 17090
 TELEPHONE 582-8200
 FAX 582-8208
 TOWNSHIP MEETING 2nd Tuesday, 7:00 p.m.
 PLANNING COMMISSION MEETING 1st Tuesday, 7:00 p.m.
 POPULATION 5,269
 MILEAGE 63
 EMAIL ADDRESS office@carrolltwp.org

SUPERVISORS

Charles Thiemann, Chairman
 5307 Spring Road, Shermans Dale, PA 17090 307-6374
 Kirby Kitzer, Vice-Chairman
 7214 Spring Road, New Bloomfield, PA 17068 582-4872
 Richard Baum, Supervisor
 335 Church Road, Shermans Dale, PA 17090 576-1911

SECRETARY/TREASURER

Barbara Clark
 50 Rambo Hill Road, Shermans Dale, PA 17090 582-8200

TAX COLLECTOR

Betty Radle
 1210 Mountain View Road, Shermans Dale, PA 17090 582-3425

AUDITORS

Jed Nessler
 216 Rambo Hill Road, Shermans Dale, PA 17090
 Steve Kralik
 72 Pine Tree Lane, Shermans Dale, PA 17090
 VACANT

SOLICITOR

Linus Fenicle, Smigel, Anderson & Sacks, LLP
 4431 N. Front St, 3rd Floor, Harrisburg, PA 17110 234-2401

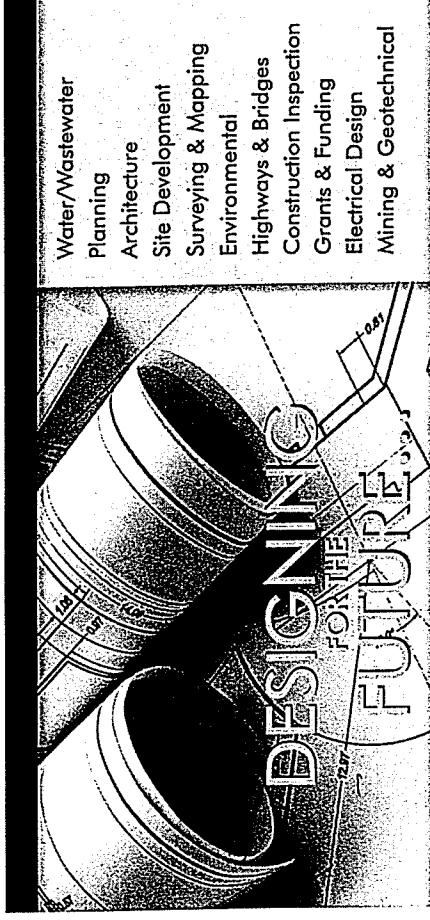

www.eadsgroup.com
 717.248.0265

THE EADS GROUP

Engineering, Architecture & Design Services

Altoona • Clarion • Johnstown • Lewistown • New Brighton
 Pittsburgh • Somerset • Cumberland • Morgantown

**A Big Thank You
 to our Advertisers!**

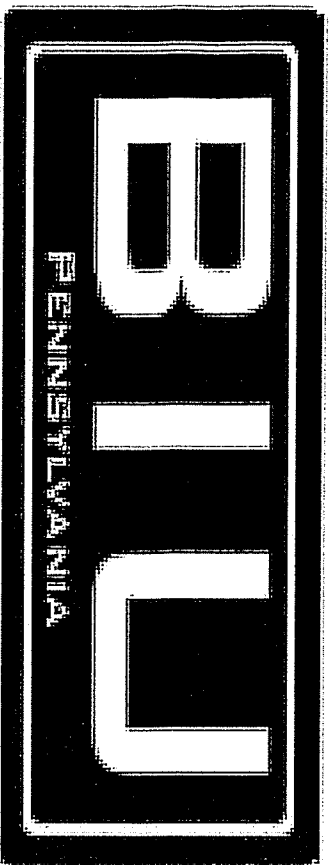

BUILDING INSPECTION UNDERWRITERS

**25 EAST McCLURE STREET
NEW BLOOMFIELD, PA 17068**

PHONE: 717-582-4483

FAX: 717-582-4431

<p>UCC Building Code Services Inspections Plans Examination Building Electrical Plumbing Mechanical Energy Accessibility</p>
--

WWW.BIUPA.COM

CARROLL TOWNSHIP (continued)

- ENGINEER**
 Fredrick Sieber Associates, Inc.
 New Bloomfield, PA 17068 275-7531
- SEWAGE ENFORCEMENT OFFICER**
 Lenny Sizer, Fredrick Sieber Associates, Inc.
 New Bloomfield, PA 17068 275-7531
- CODE ENFORCEMENT OFFICER**
 Lenny Sizer, Fredrick Sieber Associates, Inc.
 New Bloomfield, PA 17068 275-7531
- ZONING HEARING BOARD**
 William Richey, Jr.
 7244 Spring Road, Shermans Dale, PA 17090 582-4326
 J.C. Smith
 40 Old State Road, Shermans Dale, PA 17090
 John Sledzinski, Jr.
 241 Sled Drive, Shermans Dale, PA 17090
- PLANNING COMMISSION**
 Dennis Thiemann
 5307 Spring Road, Shermans Dale, PA 17090
 James Lucas
 26 Allen Drive, Shermans Dale, PA 17090
 Nina Fitchet
 6769 Spring Road, Shermans Dale, PA 17090
 Ranee Gardell
 212 Creek Road, Shermans Dale, PA 17090
- EMERGENCY MANAGEMENT COORDINATOR**
 Kirby Kiter
 7214 Spring Road, New Bloomfield, PA 17068 582-4872

CENTRE TOWNSHIP

BUILDING LOCATION 2971 Cold Storage Rd., New Bloomfield, PA 17068
 TOWNSHIP ADDRESS 2971 Cold Storage Rd, New Bloomfield, PA 17068
 TELEPHONE 582-8784
 FAX..... 582-8896
 TOWNSHIP MEETING..... 1st Tuesday, 7:00 p.m.
 PLANNING COMMISSION MEETING..... Last Monday, 7:30 p.m.
 POPULATION2491
 MILEAGE.....35.26
 EMAIL ADDRESS centretownship2971@gmail.com
 WEBSITE centretwpperryco.com

SUPERVISORS

Jason Kelly, Vice-Chairman
 748 Shermans Valley Road, New Bloomfield, PA 17068.. 554-8851
 Colin D. Reynolds, Chairman
 190 Kathryn Drive, New Bloomfield, PA 17068 582-8784
 Ricky L. Burkholder
 2431 Laurel Grove Road, New Bloomfield, PA 17068 226-0535

SECRETARY/TREASURER

Diana McPherson
 2971 Cold Storage Road, New Bloomfield, PA 17068 582-8784

TAX COLLECTOR

Maria A. Reising-Metz
 655 Clouser Hollow Road, New Bloomfield, PA 17068..... 582-2301

AUDITORS

Renee Reynolds
 190 Kathryn Drive, New Bloomfield, PA 17068
 Kyle McNaughton

SOLICITOR

Linus Fenicle, Reager & Adler
 2331 Market Street, Camp Hill, PA 17011 763-1383

FREDERICK, SEIBERT & ASSOCIATES

LOCAL OFFICE:
New Bloomfield 717-275-7531

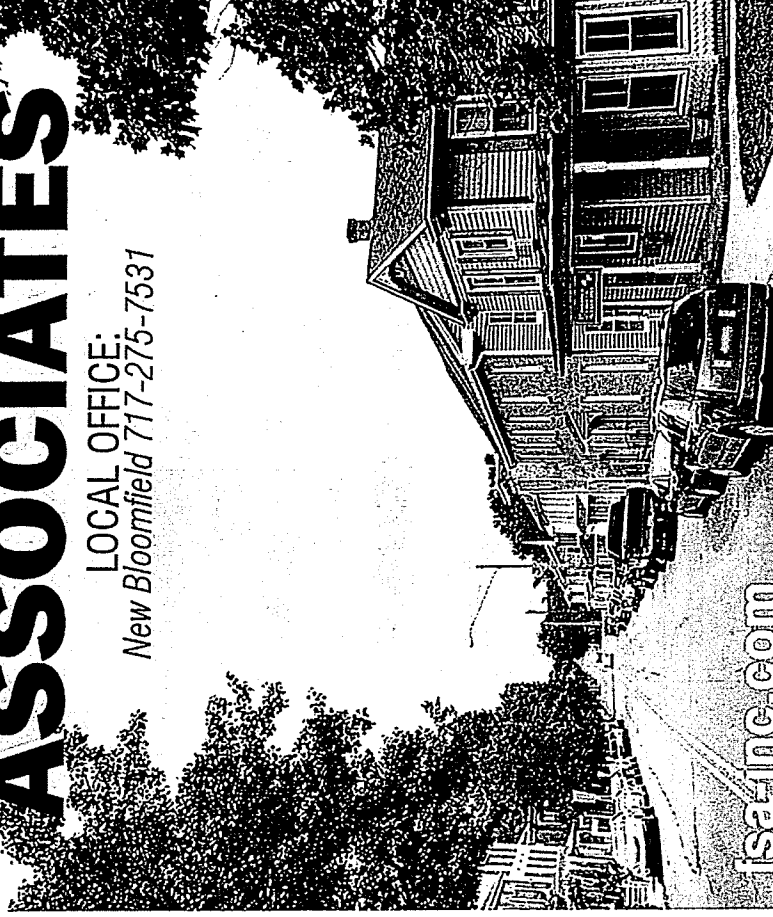

CIVIL ENGINEERING
 LAND SURVEYING
 LANDSCAPE ARCHITECTURE

HAGERSTOWN, MD • GREENCASTLE, PA • CARLISLE, PA • NEW BLOOMFIELD, PA



Jay Fulkroad and Sons, Inc.

We specialize in:
 Stone Asphalt Paving
 General Construction

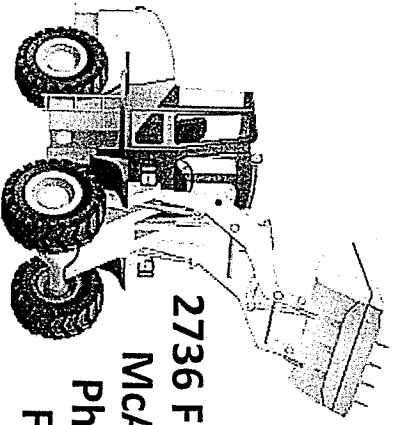

2736 Free Spring Church Road
 McAllisterville, PA 17049
 Phone: 717-463-3701
 Fax: 717-463-9266

CENTRE TOWNSHIP (continued)

SEWAGE ENFORCEMENT OFFICER Juniata Sewage Committee.....	436-9894
ALTERNATE SEWAGE ENFORCEMENT Juniata Sewage Committee.....	436-9894
PLANNING COMMISSION	
Reed Hoffman 88 Stillbee Lane, Newport, PA 17074.....	582-8784
Bill Roman, Secretary 1080 State Park Road, Newport, PA 17074.....	582-2676
Wayne Felger 183 Juniata Furnace Lane, Newport, PA 17074.....	582-8784
Ed Kent, Chairman 3335 Little Buffalo Road, Newport, PA 17074.....	582-8784
Ron Whiskers 208 Tapeworm Road, New Bloomfield, PA 17068.....	582-8784
Nathan Bragunier 2147 Jericho Road, New Bloomfield, PA 17068.....	582-8784
ENGINEER	
Gibson-Thomas 3552 Gettysburg Road, Camp Hill, PA 17011.....	612-9880

☎ (814) 215-1076 ✉ tr@usmuni.com

TAMI REYNOLDS
ACCOUNT MANAGER

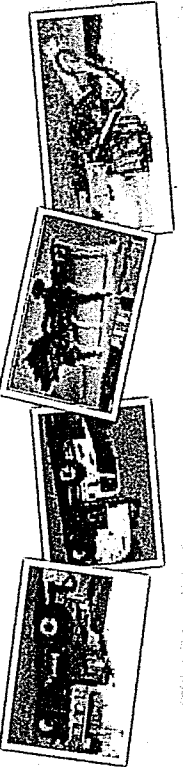

LET US HELP YOU
 GET THE JOB DONE RIGHT.

Road Maintenance Equipment
 Sewer Jetters, Vac Units & Camera Units
 Snow Equipment
 Street Sweepers
 Mowing & Leaf Equipment
 Truck Bodies

10383 Roytown Road, Huntingdon, PA | 161 Glamis Circle, King of Prussia, PA | 1519 Evans City Road, Evans City, PA

www.usmuni.com



GREENWOOD TOWNSHIP

BUILDING LOCATION..... 17 Pines Drive, Millerstown, PA 17062
TOWNSHIP ADDRESS..... P.O. Box 616, Millerstown, PA 17062
TELEPHONE 589-7204
TOWNSHIP MEETING..... 3rd Wednesday, 7:00 p.m.
PLANNING COMMISSION MEETING..... 1st Monday, 6:30 p.m.
POPULATION 1010
MILEAGE.....39

SUPERVISORS

Dan Cameron
601 Mountain Road, Millerstown, PA 17062..... 589-7170
Lewis Morrow, Chairman
409 Mountain Road, Millerstown, PA 17062..... 589-7483
Kyle Beaver, Vice-Chairman
304 Mountain Road, Millerstown, PA 17062..... 636-3125

SECRETARY

Katy Black
608 Mountain Rd., Millerstown, PA 17062..... 589-7417

TAX COLLECTOR

Diane Brinser
19 Dead End Road, Millerstown, PA 17062..... 589-3801

AUDITORS

Greg Schreiber
354 Owl Hollow Rd., Millerstown, PA 17062 589-3911
Lori Comp
107 Centerville Road, Millerstown, PA 17062..... 589-7332
Gil Davis, Chairman
105 Reward Road, Millerstown, PA 17062..... 589-7331

SOLICITOR

Don Zagurskie
117 Main Street, PO Box 0, Mifflin, PA 17058 436-8044

ENGINEER
VACANT

Cupp Insurance Agency Inc

Serving Perry County since 1927

New Bloomfield, PA 17068

Tel: (717) 582-8101

email: info@cuppagency.com

BUSINESS – FARMS ~ HOME – AUTO – LIFE

SPECIALIZING IN MUNICIPAL COVERAGE

*Insuring your way of life
is our Business*

Call us: Dave,
Wanda, Missy,
Robin or Skyler

**Your
hometown
bank through
every season.**

Serving you

**since
1864.**



PennianBank®

Redefining Banking®

717-436-2144 | PENNIAN.BANK

Member
FDIC
EQUAL HOUSING
LENDER
Bank NMLIS 561538

Connect with us:



GREENWOOD TOWNSHIP (continued)

SEWAGE ENFORCEMENT OFFICER
Juniata Sewage Committee

392 N. Ridge Road, Mifflintown, PA 17059 436-9094

PLANNING COMMISSION

Dave Griswold

622 Perry Valley Rd., Millerstown, PA 17062 589-3498

Thomas Balthaser

472 Old Ferry Rd., Millerstown, PA 17062 589-7253

Robert Bendorf

150 Reward Rd., Millerstown, PA 17062 589-7115

Roger Dressler

115 Owl Hollow Road, Millerstown, PA 17062 589-3973

Roger Musselman

668 Mountain Rd., Millerstown, PA 17062 589-3823

Kylie Cameron, Secretary

601 Mountain Rd., Millerstown, PA 17062 589-7170

ZONING OFFICER

Dave Griswold

622 Perry Valley Road, Millerstown, PA 17062 589-3498

ZONING HEARING BOARD

Doug Sarver

188 Centerville Road, Millerstown, PA 17062 439-5801

Charles Markle, Alternate

398 Owl Hollow Rd., Millerstown, PA 17062 589-3750

Sally Tengeres

175 Reward Road, Millerstown, PA 17062 589-7396

Cody Wolfe

579 Perry Valley Road, Millerstown, PA 17062

EMERGENCY MANAGEMENT COORDINATOR

Mark Stroup

517 Perry Valley Road, Millerstown, PA 17062 589-7742

HOWE TOWNSHIP

BUILDING LOCATION..... 22 Cherry Road, Liverpool, PA 17045
 TOWNSHIP ADDRESS..... 22 Cherry Road, Liverpool, PA 17045
 TELEPHONE 444-3045
 TOWNSHIP MEETING..... 1st & 3rd Thursday, 5:00 p.m.
 PLANNING COMMISSION MEETING..... 4th Monday, 6:00 p.m.
 POPULATION 393
 MILEAGE..... 5.00
 EMAIL ADDRESS..... howetwp@pa.net or howetownship.com

SUPERVISORS

Dale Beaver - Chairman
 3 Herr Court, Newport, PA 17074 574-6573
 Steve Smith
 225 Juniata Parkway E., Newport, PA 17074
 Charles Burd
 62 W. Shortcut Road, Newport, PA 17074..... 648-9970

SECRETARY/TREASURER

Nancy Cangjoli
 650 Bucks Church Road, Newport, PA 17074 444-2211

TAX COLLECTOR

Juanita Zeigler
 119 Juniata Pkwy E, Newport, PA 17074..... 567-2232
 howetax@yahoo.com

AUDITORS

Vacant

SOLICITOR

Stock & Leader - David Jones
 York, PA 849-4128

We Fit All Your Municipal Insurance Needs... Perfectly.

- Package Insurance
- Property Insurance
- Liability Insurance
- Auto Insurance
- Municipal Pooling
- Treasurer Bonds
- Police Professional Insurance
- Errors & Omissions Insurance
- Workers' Compensation Insurance
- Loss Control
- Property Valuations
- Risk Management Services
- Self-Insurance Administration
- Blanket Employee Bonds
- Group Life Insurance
- Health Insurance
- Disability Insurance

As Pennsylvania's largest provider of municipal insurance, H.A. Thomson has the resources to bring you the best coverage at the lowest cost. Our team of experts can meet all your insurance needs, while eliminating costly gaps and overlaps.

At H.A. Thomson, we understand the insurance responsibilities facing Pennsylvania's municipalities. That's why, since 1934, we've been making municipal insurance easy, convenient and cost-effective—providing total coverage and total peace of mind.

To learn more about how H.A. Thomson can serve you, call us at 1-800-362-1011 today for more information.

H.A. THOMSON

• RISK MANAGEMENT SERVICES •

961 Portstown Pike • Chester Springs, PA 19425

1-800-362-1011 • FAX 610-321-1001 • www.hathomson.com

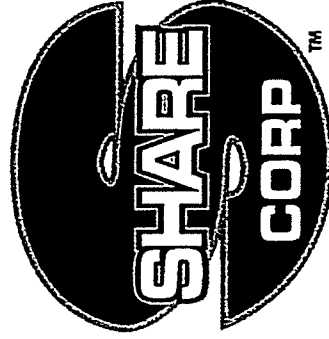

Ralph Fluharty

Sales Engineer

Mifflinburg, PA 17844

Phone: 570.966.3705

Cell Phone: 570.939.2854

Fax: 570.966.3705

Voice Mail: 800.748.1812 ext. 7717

SHARE CORPORATION

SPECIALTY CHEMICALS, TOOLS,
 TRAFFIC SIGNS, SAFETY & EYEWEAR

HERCULES HARDWARE

P.O. BOX 245013

MILWAUKEE, WI 53224-9513 • (800) 776-7192

Visit our website at www.sharecorp.com

WOSB

Women Owned Small Business

A Hometown Banking Center

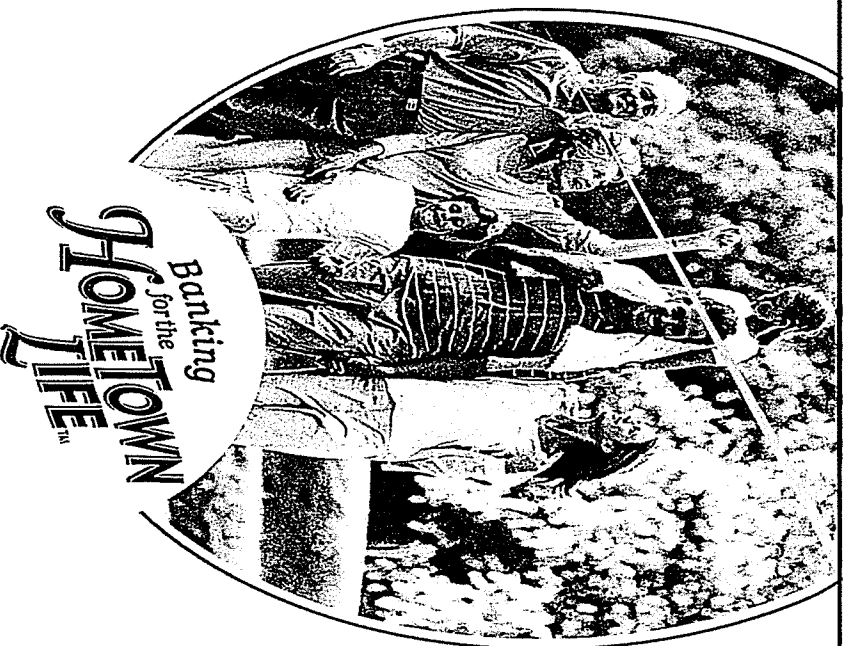

Were a hometown banking center. With us your money stays right here in our area where it belongs. We reinvest your deposit locally. So if you're interested in banking for the hometown life, we're your bank.

LB
 THE BANK OF
LANDISBURG
Established 1893

NMIS #665200

www.bankoflandisburg.com



HOWE TOWNSHIP (continued)

ENGINEER
 HRG Engineering Services - Mike Hess
 369 East Park Drive, Harrisburg, PA 17111 564-1121

SEWAGE ENFORCEMENT OFFICER
 Juniata Sewage Committee
 Mifflintown, PA..... 436-9094

PLANNING COMMISSION:
 Terry Heller, Chair
 70 Red Hill Road, Newport, PA 17074 567-6774

Jamie McHenry
 174 Juniata Pkwy E, Newport, PA 17074
 Pam Pollock
 69 W. Shortcut Road, Newport, PA 17074
 Melissa Zeiders
 376 Juniata Pkwy E, Newport, PA 17074

ZONING OFFICER/CODE ENFORCEMENT
 Central Keystone COG..... 877-457-9401
 1610 Industrial Blvd., Suite 400A, Lewisburg, PA 17837

ZONING HEARING BOARD:
 Enos Herr
 Mark Hoover

EMERGENCY MANAGEMENT COORDINATOR
 Tim Moench..... 215-900-0911
 86 Meadow Grove Road, Newport, PA 17074

JACKSON TOWNSHIP

BUILDING LOCATION.....890 Fowler Hollow Rd., Blain, PA 17006
 TOWNSHIP ADDRESS.....890 Fowler Hollow Rd., Blain, PA 17006
 TELEPHONE.....536-3675
 TOWNSHIP MEETING Last Thursday except Oct 24, Nov 21 & Dec 19; 6:30 PM
 POPULATION.....545
 MILEAGE.....17.5
 EMAIL ADDRESS.....jacksontwp@pa.net

SUPERVISORS

William A. Smith, Chairman
 5557 Couchtown Road, Blain, PA 17006.....536-3675
 Brad A. Smith, Vice-Chairman
 5587 Couchtown Road, Blain, PA 17006.....536-3795
 Jeffrey A. Trout
 632 Trout Farm Lane, Blain, PA 17006.....536-3297

SECRETARY/TREASURER

Darlene Smith
 5557 Couchtown Road, Blain, PA 17006.....536-3675

TAX COLLECTOR

Vickie K. Rice
 212 Bernheisel Road, Blain, PA 17006.....536-3685

AUDITORS

Amanda Kuhn
 220 Seagertown Road, Blain, PA 17006.....536-3004
 Zachary Kuhn
 220 Seagertown Road, Blain, PA 17006.....536-3004

SOLICITOR

David F. Rice
 212 Bernheisel Road, Blain, PA 17006.....536-3685



Stahl Sheaffer designed the structure for the
 AIV Trail Bridge, including a 20' x 5' precast
 concrete culvert and the foundation for a 150'
 prefabricated steel truss bridge.

Proud to Support the Perry County Association of Township Officials!

- Bridge and Tunnel Design
- Building Structural Engineering
- Construction Inspection
- Environmental Services
- Geotechnical Engineering
- GIS Applications
- Roadway Design and Management
- Site Engineering
- Survey and 360° Scanning
- Traffic Engineering

Local Office: 4431 N. Front Street, Suite 102, Harrisburg, PA 17110

717.510.7223 | stahlsheaffer.com

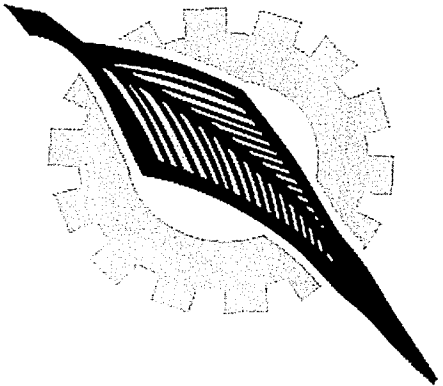

Capital Tax Collection Bureau

JACKSON TOWNSHIP (Continued)

SEWAGE ENFORCEMENT OFFICER
Juniata Sewage Committee

3044 Middle Ridge Rd, Rm #4, Honey Grove, PA 17035 ... 436-9094

PLANNING COMMISSION – PERRY COUNTY PLANNING COMMISSION

EMERGENCY MANAGEMENT COORDINATOR
Wesley Smith

91 Andersonburg Road, Loysville, PA 17047 536-0073

ENGINEER

Pennoni Assoc. Inc.

704 Lisburn Road, Camp Hill, PA 17011 975-6481

Huntingdon County Office

18839 Sandy Ridge Station Suite 2

Orbisonia, PA 17243

Phone: 814-447-3111

Fax: 814-447-3113

Perry County Office

8391 Spring Rd Suite 3

New Bloomfield, PA 17068

Phone: 717-957-7281

Fax: 717-957-7295

- Earned Income Tax (Current and Delinquent)
- Local Service Tax
- Per Capita Tax

WWW.CAPTAX.COM

Serving Central PA for over 40 years
with personalized service!

JUNIATA TOWNSHIP

BUILDING LOCATION16 Milford Road, Newport, PA 17074
 TOWNSHIP ADDRESS16 Milford Road, Newport, PA 17074
 TELEPHONE 567-9514
 FAX..... 567-9514
 TOWNSHIP MEETING ... (6:30 DST).....2nd Wednesday, 7:30 p.m.
 PLANNING COMMISSION MEETING1st Wednesday, 7:30 p.m.
 POPULATION1537
 MILEAGE.....33
 E-MAIL ADDRESSjuniatatwp@embarqmail.com

SUPERVISORS

Crist Hess, Chairman
 981 Cemetery Road, Newport, PA 17074 567-6758
 Brett Beaver
 54 Numer Road, Newport, PA 17074 567-7969
 John Hess, Jr.
 19 Campbell Road, Newport, PA 17074 567-7943

SECRETARY/TREASURER

Tara Hinkle
 3010 Creek Road, Newport, PA 17074 567-6524

TAX COLLECTOR

Peggy McNaughton
 259 Honeysuckle Hollow Road, Newport, PA 17074 567-6022

AUDITORS

Stewart Kirk
 437 Hollow Road, Newport, PA 17074 582-3583
 Evan Deimler
 633 Numer Road, Newport, PA 17074 991-6925
 Bradley Simpson
 21 Milford Road, Newport, PA 17074 422-4036

SOLICITOR

Dissinger & Dissinger
 400 South State Road, Marysville, PA 17040 957-3474

DS&T

DEIBLER
 STRAUB &
 TROUTMAN

KEYSTONE®

CHEMUNG SUPPLY CORPORATION

**Highway Supplies
 Installation & Assembly Services
 Manufacturing/Fabricating**

- Snow Plow Wear Parts
- Pewag Tire Chains and Accessories
- Aluminum Structural Plate and Box Culverts
- Corrugated Metal Pipe
- Large Heavy Steel Culvert Pipes
- Guide Rail / Box Beam / Bridge Rail
- Complete Guide Rail Material and Installation
- Bridge Decking - Corrugated, Open Grating, Wood
- Steel Plate, Beams, Angle, and Channel
- Signs and Sign Post (U-Channel, Square, Round)
- Safe-Hit Reflector Posts
- Rake Teeth / Geotextiles / Gabions
- Smith Spreaders / Tailgate Spreaders
- Work Zone Signs / Stands/ Barricades
- Safety Cones / Manhole Risers and Rings

Steve Campbell
 Southeast PA Sales
 Direct: 814-321-2292
 scampbell@chemungsupply.com

Pennsylvania Office:
 102 Creek Road
 Carlisle, PA 17013
 Phone: 800-733-5508

EVOLUTION EDGES
 A DIVISION OF CHEMUNG SUPPLY

sabre

Providing Solutions for our Customers since 1931

SEI

For Your Equipment Needs Call On

Scott Schatz

STEPHENSON

EQUIPMENT, INC.

mobile: 717-554-0891

sschatz@stephensonequipment.com
www.stephensonequipment.com



COSTARS™



Equipment Sales, Rental, Parts and Service

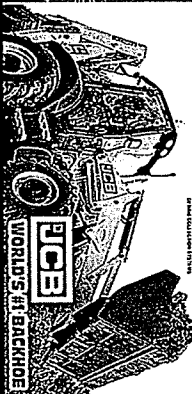

Driven by Customer Satisfaction Since 1957



MOR EQUIPMENT

A Division of **SEI**
Stephenson Equipment

For Your Truck Equipment Needs Call On

Rick Springer

mobile: 717-712-8761

rspringer@stephensonequipment.com

STARS PARTNER
 WITH ALL OUR
 EQUIPMENT
 VENDORS



COSTARS



JS
 TRUCK BODIES
 & ROLLERS

FORCE
 America's
 HI-WAY
 EQUIPMENT



WEST
 EQUIPMENT

GLADHILL
 EQUIPMENT



HENDERSON
 EQUIPMENT

TARCO
 EQUIPMENT



BRINEX
 Xtreme

TARCO
 EQUIPMENT



a division of
SEI
 STEPHENSON
 EQUIPMENT, INC.

JUNIATA TOWNSHIP (continued)

PLANNING COMMISSION

- Joann Wood 567-2042
- 22 Milford Road, Newport, PA
- John Hess, Jr., Chairman 567-7943
- 19 Campbell Road, Newport, PA 17074
- Chris Hinkle, Secretary 567-6524
- 3010 Creek Road, Newport, PA 17074
- John Fry, Vice-Chairman 567-9514
- 7011 Creek Road, Newport, PA 17074
- Stephen Warner 567-9514
- 9890 Creek Road, Newport, PA 17074

ZONING OFFICER – SEWAGE ENFORCEMENT OFFICER – ENGINEER

- Leonard Sizer, FSA 275-7531
- P.O. Box 357, New Bloomfield, PA 17068

ALTERNATE SEWAGE ENFORCEMENT OFFICER & ZONING OFFICER

- Matt Eck, FSA 275-7531
- P.O. Box 357, New Bloomfield, PA 17068

ZONING HEARING BOARD

- William Roberts 567-7216
- Homestead Road, Newport, PA 17074
- Robert W. Gabel 215-8726
- 30 Gabel Road, Newport, PA 17074
- John Mauer 567-6553
- 600 Timber Road, Newport, PA 17074
- Hazel Barkley 567-6428
- 18 Milford Road, Newport, PA 17074
- Robert Rolston 567-6205
- 800 Pond Road, Newport, PA 17074

EMERGENCY MANAGEMENT COORDINATOR

- John Hess 567-7943
- 19 Campbell Road, Newport, PA 17074

LIVERPOOL TOWNSHIP

BUILDING LOCATION 1121 Ridge Road, Liverpool, PA 17045
TOWNSHIP ADDRESS 1121 Ridge Road, Liverpool, PA 17045
TELEPHONE 444-7321
TOWNSHIP MEETING 1st Monday, 7:00 p.m.
PLANNING COMMISSION MEETING 3rd Monday, 7:00 p.m.
POPULATION 1057
MILEAGE 30
E-MAIL ADDRESS liverpoolperry17045@gmail.com

SUPERVISORS

Christopher Goodling, Road Master
180 State Route 235, Liverpool, PA 17045 444-2591
Darwin Hess, Chairman
2622 State Route 17, Liverpool, PA 17045 444-7100
Patrick Corkle, Sr., Vice-Chairman
1879 State Route 17, Millerstown, PA 17062 582-6931

SECRETARY/TREASURER

Donna Wood
2067 Long Hollow Road, Millerstown, PA 17062 694-3648
TAX COLLECTOR
Anna Marie Sassaman
1837 State Route 17, Millerstown, PA 17062 589-7102

AUDITORS

Andrew Wert
110 Fishing Rod Road, Liverpool, PA 17045
Kendra McKee
1336 Perry Valley Road, Liverpool, PA 17045 444-3981
Carl A. Curchoe
2049 Race St. Ext., PO Box 415, Liverpool, PA 17045 444-3529

SOLICITOR

Linus Fenicle

GUIDANCE

YOU CAN COUNT ON

*Financial Statement Audits • Yellow Book & Single Audits
DCED Audits • Forensic Audits • Payroll Processing
Accounting Standards Implementation • ARPA Funding
Outsourced CFO/Controller • QuickBooks Consulting
Organizational Advisory • HR Consulting*



717.263.3910 | SEK.com

CAMP HILL | CARLISLE | CHAMBERSBURG | HAGERSTOWN | HANOVER | YORK

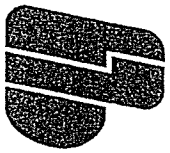

Lancaster truck bodies
Making trucks work smarter, not harder since 1936.

COSTAR# 025-622-436 Contact Vendor

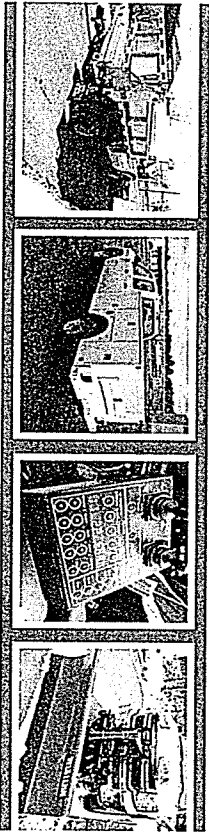

- Dump Bodies
- Aluminum & Steel Service Bodies
- Truck Caps
- Stake Bodies
- Cranes & Crane Bodies
- Van Bodies
- Snow & Ice Equipment
- Toolboxes and Ladder Racks
- Van Interiors
- Liftgates,
- Tarps & Other Accessories

Kay Whitson Dohm

Office: (800) 732-0004

Cell: (717) 629-6426

kwhitson@lancastertruckbodies.com

310RichardsnDrive, Lancaster, PA 17603 | www.lancastertruckbodies.com

LIVERPOOL TOWNSHIP (continued)

ENGINEER/ZONING OFFICER

Jerry Spase

11 Deer Trail Circle, Liverpool, PA 17045 444-7694

SEWAGE ENFORCEMENT OFFICER

Juniata Sewer Committee

3044 Middle Ridge Rd, Honey Grove, PA 17035 436-9094

PLANNING COMMISSION

Dave Pundock

15 Grandview Circle, Liverpool, PA 17045 609-980-0600

Raymond Sheaffer, Jr.

438 Nekoda Road, Millerstown, PA 17062

Kevin Sassaman

1837 State Route 17, Millerstown, PA 17062

Robert Trego

345 Barners Road, Liverpool, PA 17045 636-2273

Ryan Hoff

215 Barners Road, Liverpool, PA 17045 444-3513

ZONING HEARING BOARD

Douglas Rumbaugh

432 Iowa Hollow Road, Millerstown, PA 17062 444-3300

Grace Shiffer (Alternate)

962 Owl Hollow Road, Millerstown, PA 17062 444-2582

Jason Saylor

261 State Route 235, Liverpool, PA 17045

Read Bachman

456 Nekoda Road, Millerstown, PA 17062

MILLER TOWNSHIP

BUILDING LOCATION... 554 Old Limekiln Lane, Newport, PA 17074
TOWNSHIP ADDRESS... 554 Old Limekiln Lane, Newport, PA 17074
TELEPHONE 567-9730
FAX..... 567-9730
TOWNSHIP MEETING Last Tuesday, 6:00 p.m.
PLANNING COMMISSION MEETING..... 2nd Tuesday, 7:00 p.m.
POPULATION 954
MILEAGE..... 22
EMAIL ADDRESS..... millertw@ptd.net

SUPERVISORS

Nicholas McAlicher
 201 Lower Bailey Road, Duncannon, PA 17020..... 743-9589
 Scott Seltzer
 5 Lower Bailey Road, Duncannon, PA 17020 512-0072
 Brian Kish
 455 Mahanoy Valley Road, Duncannon, PA 17020..... 585-8323

SECRETARY/TREASURER

Eloise Miller, Assistant
 682 Mahanoy Valley Road, Duncannon, PA 17020..... 919-1618

TAX COLLECTOR

Lois Schoppy
 554 Old Limekiln Lane, Newport, PA 17074..... 567-8373

AUDITORS

Victoria Twigg
 482 Old Limekiln Lane, Newport, PA 17074..... 636-5908
 Kinga McCoy
 1069 Mahanoy Valley Road, Duncannon, PA 17020..... 639-1367
 Tammy Tumbaugh
 1973 Newport Road, Newport, PA 17074 275-2894

SOLICITOR

Mark Allshouse
 15 Cove Road, Marysville, Pa 17053 582-4006

Let's invest in you.
 We're here – for our largest districts and smallest municipalities; for the market-savvy and the first-time investors; for the long haul and the short term.

We're here for you.
 40 years of serving local governments and schools
 Liquid and long-term options
 Dedicated service team
 Variety of portfolio choices
 Cash management services

PLGIT.com
800-572-1472



This information is for institutional investor use only, not for further distribution to retail investors, and does not represent an offer to sell or other security. Investors should consider the investment objectives, risks, charges and expenses before investing in any of the Trust's portfolios. Information is available in the current information statement, which should be read carefully before investing. A copy of the information statement is available on the Trust's website at www.plgit.com. While the PLGIT and PLGIT/PRIME portfolios seek to maintain a 50% investment in publicly traded securities, the PLGIT/PRIME portfolio seeks to achieve a net asset value of \$1.00 per share at its stated maturity, it is possible to lose money investing in the Trust's portfolios as a result of fluctuations in the value of the underlying assets. The Trust's portfolios are a member financial industry regulatory authority (FINRA) (www.finra.org) and Securities Investor Protection Corporation (SIPC) (www.sipc.org). PLGIT Asset Management LLC - an Equal Opportunity Employer. PLGIT, PLGIT-Class Shares, PLGIT/PRIME and PLGIT/PRIME Class Shares are the Pennsylvania Local Government Investment Trust.

E. M. KUTZ, INC.

Meeting all of your Municipal Truck & Snow Equipment Needs











Dump Bodies • Utility Bodies • Platform Bodies
 Snowplows • Salt Spreaders
 Mild Steel, Carbide & Rubber Cutting Edges
 Hoists • Toolboxes • Central Hydraulics
 Tire Chains • Tarps
 Tire Chains • Tire Chain Systems
 Industrial Chains & Binders
 Truck Lighting & Strobe Light Systems
 PTOs & Parts • Pumps & Parts
 Plow & Spreader Parts

2456 Morgantown Road
 Reading, PA 19607
 610-775-3528
 Email: sales@emkutz.com

801 Front Street
 Whitehall, PA 18052
 610-264-9777
 Website: www.emkutz.com

Celebrating 70 Years!



COORDINATE PA IS THE NEXT GENERATION OF UTILITY COORDINATION

Coordinate PA is a web application developed by Pennsylvania One Call System to support public works, utility project planning and utility coordination within the Commonwealth of Pennsylvania. Users utilize a spatial, map-based system to view underground utility and public works projects, identifying opportunities for coordination and collaboration when projects overlap in space and time.

Coordinate PA Benefits:

- Define projects using a web application (No special software required!) Store project data and records in a secure repository
- Gather and disseminate information to a broader range of stakeholders beyond project planners and public works officials
- Coordinate and collaborate on projects outside your scope of responsibility, saving money and improving service for all parties
- Request meetings and upload documents associated with a complex project

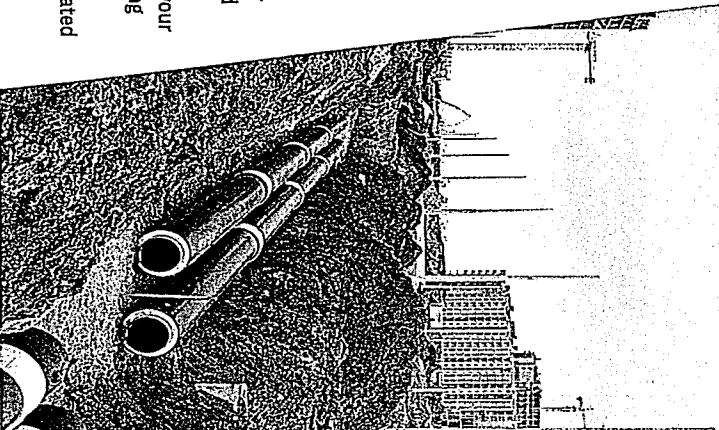

MILLER TOWNSHIP (continued)

SEWAGE ENFORCEMENT OFFICER
Juniata Sewage Committee

3044 Middle Ridge Rd, Rm #4, Honey Grove, PA 17035 ... 436-9094

ENGINEER

FSA

PO Box 357, New Bloomfield, PA 17068 275-7531

PLANNING COMMISSION

Bonnie Heisey, Secretary

250 Alice Lane, Newport, PA 17074 567-7708

Mike Zentichko

2209 Newport Road, Newport, PA 17074

Donna Speis

1971 Newport Road, Newport, PA 17074 204-5000

Justan Turnbaugh, Chairman

1973 Newport Road, Newport, PA 17074 315-1902

Dale McCoy

1069 Mahanoy Valley Road, Duncannon, PA 17020.. 814-282-4685

EMERGENCY MANAGEMENT COORDINATOR

Clark Steele

70 Upper Bailey Road, Newport, PA 17074 514-9692

ROADMASTER

Elvin Miller

682 Mahanoy Valley Road, Duncannon, PA 17020 836-2046

CODE ENFORCEMENT OFFICER

Harry Nazzaro 877-4450

NORTHEAST MADISON TOWNSHIP

BUILDING LOCATION..... 979 Quarry Rd., Loysville, PA 17047
 TOWNSHIP ADDRESS.....P.O. Box 905, Loysville, PA 17047
 TELEPHONE.....789-9175...or...636-2559
 TOWNSHIP MEETING..... 1st Tuesday, 7:30 p.m.
 POPULATION.....786
 MILEAGE.....11.68

SUPERVISORS

Harold E. Palm, Chairman
 5332 Fort Robinson Road, Ickesburg, PA 17037 789-3071
 Carl E. McMillen
 102 Dwight Drive, Loysville, PA 17047 574-4832
 Dennis R. Palm
 200 Old Baltimore Trail, Ickesburg, PA 17037 789-3865

SECRETARY/TREASURER

Sarah M. Cramer
 5909 Shermans Valley Road, Loysville, PA 17047 275-4638

TAX COLLECTOR

Barbara A. Herr
 5260 Fowler Hollow Road, Blain, PA 17006 536-9979

AUDITORS

Joy Enck
 P.O. Box 122, Loysville, PA 17047..... 789-3804
 Amy Kretzing
 6651 Tuscarora Path, Loysville, PA 17047 789-9436

SOLICITOR

William R. Bunt
 P.O. Box 336, New Bloomfield, PA 17068 582-8195

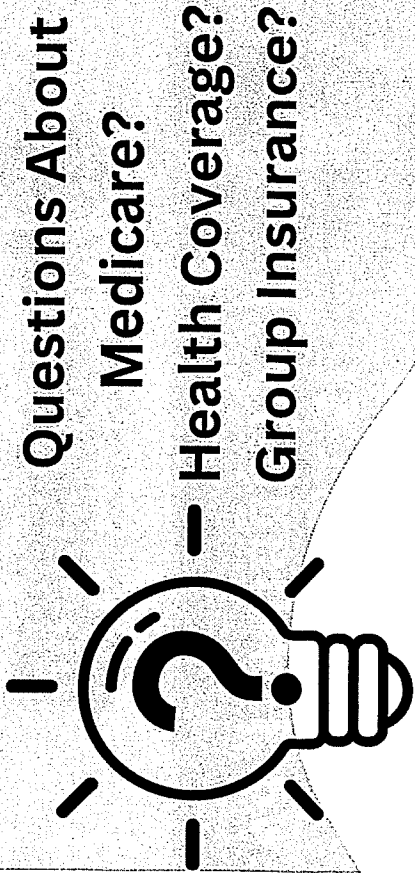

Kathy is Medicare certified and here to help you, your family, and employees navigate health coverage.

Consultations are always free!



Trapp Health Insurance Advisors

Kathy Trapp
 717-608-7161
 kathytrapp.com
 kathy@kathytrapp.com

The One-Two Punch for Township Employee Retirement Security

PSATS 401(a) Plan Benefits

- **No municipal risk:** You're never on the hook for investment shortfalls.
- **Flexible eligibility:** Choose who participates.
- **Contribution options:** Set fixed percentages or flat dollar amounts.
- **Portability:** Easily transfer assets to another plan.
- **Convenient access:** 24/7 online account tools and quarterly reports.
- **State aid:** Qualifying townships get financial support.

Maximize savings with PSATS Trustees Retirement Services



PA MUNICIPALITIES PENSION TRUST

Call us toll-free at (800) 382-1268 for enrollment information.
www.psatsinsurance.org

PSATS 457(b) Plan Benefits

- **Open to all:** Full-time, part-time, everyone can save.
- **Voluntary contributions:** Choose how much to save, with or without township match.
- **Investment choices:** Select "Do it for me" target-date funds or "Do it myself" individual options.
- **Pre-tax or Roth:** Pay taxes now or pay later; the choice is yours.
- **Boost your retirement:** Save more to replace your income when you retire.

NORTHEAST MADISON TOWNSHIP (Continued)

SEWAGE ENFORCEMENT OFFICER

J.C. Smith

40 Old State Road, Shermans Dale, PA 17090 582-2043

ALTERNATE

Dan Page & Polly Graybill

25 Dolan Hights Road, Mifflintown, PA 17059 436-2291

EMERGENCY MANAGEMENT COORDINATOR

VACANT

OLIVER TOWNSHIP

BUILDING LOCATION..... 615 S. Third St., Newport, PA 17074
TOWNSHIP ADDRESS..... P.O. Box 126, Newport, PA 17074
TELEPHONE 567-3809
FAX..... 567-7827
E-MAIL..... olivert@pa.net
TOWNSHIP MEETING..... 2nd Monday, 7:00 p.m.
PLANNING COMMISSION MEETING..... 3rd Wednesday, 7:00 p.m.
POPULATION2,043
MILEAGE.....20.69

SUPERVISORS
Ralph Lesh, III
P.O. Box 320, Newport, PA 17074..... 567-3211
Joseph R. Baker
P.O. Box 126, Newport, PA 17074..... 567-9767
Angela Howell
421 St. Samuel Rd, Newport, PA 17074 514-7581

SECRETARY/TREASURER
Jill E. Hoover
P.O. Box 126, Newport, PA 17074 567-3809

TAX COLLECTOR
Aleah Paul
851 Liberty Street, Newport, PA 17074 204-7506

AUDITORS
Marcia Ramer
181 Creekview Drive, Newport, PA 17074 567-3491
Dawn Miller
788 Sheck Drive, Newport, PA 17074..... 567-3857
Steven Metzger
881 Upper Bailey Road, Newport, PA 17074..... 567-9110

SOLICITOR
Jerry Philpott
P.O. Box 116, Duncannon, PA 17020 834-3087

WHEATFIELD TOWNSHIP (Continued)

ENGINEER
Jerry Spease
11 Deer Trail Circle, Liverpool, PA 17045 444-7694

SEWAGE ENFORCEMENT OFFICER
JC Smith
40 Old State Road, Shermans Dale, PA 17090..... 275-5296

PLANNING COMMISSION
Paul Finkenbinder
852 New Bloomfield Road, Duncannon, PA 17020..... 834-5771
Travis Clapper
549 Newport Road, Duncannon, PA 17020 810-9296
David Mills
280 Montebello Farm Road, Duncannon, PA 17020..... 834-6603
Dave Jenkins
371 Roseglen Road, Duncannon, PA 17020..... 834-9490

ZONING HEARING BOARD
Bob Hines
358 Linton Hill Road, Duncannon, PA 17020..... 834-3882
Mike Petersen
348 Linton Hill Road, Duncannon, PA 17020..... 350-3164
Marsha Snyder
816 Dellville Road, Duncannon, PA 17020 834-4810
Judy Zeiders
150 Hunkey Hollow Road, Duncannon, PA 17020 580-0248

ZONING OFFICER
Lester Nace
7 Roseglen Road, Duncannon, PA 17020..... 580-4633

EMERGENCY MANAGEMENT COORDINATOR
Kurt Hepschmidt
284 Montebello Farm Road, Duncannon, PA 17020..... 834-6981

WHEATFIELD TOWNSHIP

BUILDING LOCATION, 1280 New Bloomfield Rd, New Bloomfield, PA 17068
 TOWNSHIP ADDRESS.. 1280 New Bloomfield Rd, New Bloomfield, PA 17068
 TOWNSHIP MEETING..... 1st Monday, 7:00 p.m. 834-5467
 TELEPHONE..... 2nd Tuesday, 7:00 p.m. 3,203
 PLANNING COMMISSION MEETING..... 34
 POPULATION..... 834-0157
 MILEAGE..... wheatfld@ptd.net
 FAX.....
 E-MAIL ADDRESS.....
 SUPERVISORS
 Phillip Vogel, Vice-Chairman
 150 Loshes Run Road, Duncannon, PA 17020..... 834-6261
 James L. Fuller, Chairman
 301 Roseglen Road, Duncannon, PA 17020..... 580-3344
 Jeffrey R. Smith, Supervisor
 54 Dirt Lane, New Bloomfield, PA 17068 275-5751
 SECRETARY/TREASURER
 Rita Benner
 8093 Spring Road, New Bloomfield, PA 17068..... 385-8615
 TAX COLLECTOR
 Loraine Vogel
 150 Loshes Run Road, Duncannon, PA 17020..... 834-6261
 AUDITORS
 Loraine Walleet
 10 Barley Drive, Duncannon, PA 17020 571-0524
 Scott Shedd
 293 Montebello Farm Road, Duncannon, PA 17020..... 884-1002
 Linda Fuller
 301 Roseglen Road, Duncannon, PA 17020..... 514-6467
 SOLICITOR
 Dave Wilson
 227 High Street, Duncannon, PA 17020..... 834-3087

OLIVER TOWNSHIP (continued)

ENGINEER
 JHA Companies
 3705 Trindle Road, Camp Hill, PA 17011 303-6100
 SEWAGE ENFORCEMENT OFFICER
 Lenny Sizer - Frederick, Seibert & Associates, Inc.
 P. O. Box 357, New Bloomfield, PA 17068 275-2048
 PLANNING COMMISSION
 Trevor Myers
 226 Turkey Bird Road, Newport, PA 17074 460-5203
 Jeff Biliger
 36 Campbell Drive, Newport, PA 17074..... 567-9210
 Jill E. Hoover
 P. O. Box 126, Newport, PA 17074 567-3809
 Gerald Gabel
 1651 Olak Hall Road, Newport, PA 17074..... 567-6181
 Timothy Atherton
 735 Hillcrest Drive, Newport, PA 17074 433-8850
 ROADMASTER
 Joseph R. Baker
 P. O. Box 126, Newport, PA 17074 567-6925
 EMERGENCY MANAGEMENT COORDINATOR
 Patrick Shull
 1160 St. Samuels Road, Newport, PA 17074..... 567-9456

PENN TOWNSHIP

BUILDING LOCATION ... 100 Municipal Building Road, Duncannon, PA 17020
TOWNSHIP ADDRESS ... 100 Municipal Building Road, Duncannon, PA 17020
TELEPHONE 834-5281
FAX..... 834-6854
TOWNSHIP MEETING..... Last Wednesday, 7:00 p.m.
PLANNING COMMISSION MEETING..... 3rd Monday, 7:00 p.m.
POPULATION 3,110
MILEAGE..... 26.73
E-MAIL ADDRESS pennntp6@ptd.net

SUPERVISORS
Henry A. Holman, III
220 Cove Road, Duncannon, PA 17020 363-3674
Cliff Lindgren
315 Faculty Road, Duncannon, PA 17020..... 589-5435
Karen Potteiger
25 Sawmill Road, Duncannon, PA 17020 363-3676

SECRETARY
Helen Klinepeter
334 New Bloomfield Road, Duncannon, PA 17020 623-2624

ASSISTANT SECRETARY
Jennifer Blouch
8 Eisenhower Blvd, Duncannon, PA 17020 834-5281

TREASURER
Ann Delancey
377 Dellville Road, Duncannon, PA 17020..... 834-5281

TAX COLLECTOR
Peter Thompson
1314 State Road, Duncannon, PA 17020

SOLICITOR
Michael O'Connoe, DPM
2132 Market Street, Camp Hill, PA 17011

ENGINEER
Keller Engineering
207 Baltimore Street, Gettysburg, PA 334-9137

WATTS TOWNSHIP (continued)

ENGINEER
Jerry Spease
11 Deer Trail Circle, Liverpool, PA 17045 571-4591

SEWAGE ENFORCEMENT OFFICER
J.C. Smith
40 Old State Road, Shermansdale, PA 17090 582-2043

PLANNING COMMISSION
Tim Maus - Chairman
33 Amity Road, Duncannon, PA 17020 503-1399

Roger Wilt
164 Huggins Road, Duncannon, PA 17020
Russell Clouser
55 Notch Road, Duncannon, PA 17020
Dr. Pat Gutheil
2 Hidden Lane, Duncannon, PA 17020
Bob Mazzaro
2 Hidden Lane, Duncannon, PA 17020
Robert Whitmore

ZONING OFFICER/CODE ENFORCEMENT OFFICER
Jerry Spease
11 Deer Trail Circle, Liverpool, PA 17045 571-4591

EMERGENCY MANAGEMENT COORDINATOR
Tim Moench
86 Meadow Grove Road, Newport, PA 17074 215-900-0911

WATTS TOWNSHIP

BUILDING LOCATION..... 112 Notch Road, Duncannon, PA 17020
TOWNSHIP ADDRESS..... 112 Notch Road, Duncannon, PA 17020
TELEPHONE 834-4009
TOWNSHIP MEETING..... 1st Wednesday, 6:00 p.m.
PLANNING COMMISSION MEETING..... 2nd Wednesday, 7:00 p.m.
POPULATION 1,265
MILEAGE..... 18
E-MAIL ADDRESS wattstwp@gmail.com
WEBSITE wattstownship.org

SUPERVISORS
Karl Raudensky - Chairman
2 Cedar Lane, Duncannon, PA 17020 579-6853
Glen Smithgall
158 Huggins Road, Duncannon, PA 17020 443-2993
Darren Miller
142 Huggins Road, Duncannon, PA 17020 433-6687

SECRETARY/TREASURER
Nancy Cangiali
650 Bucks Church Road, Newport, PA 17074 444-2211

TAX COLLECTOR
Julie Myers
P.O. Box 191, New Buffalo, PA 17069 979-8921

AUDITOR
Gary Wilt
Charles Wilt
Kyle Barrick

SOLICITOR
Linus Fenicle, Reager & Adler
2331 Market St., Camp Hill, PA 17011 763-1383

PENN TOWNSHIP (Continued)

AUDITORS
Lucinda Novinger
1403 State Road, Duncannon, PA 17020 957-2840
Henry A. Holman, II
61 Holman Drive, Duncannon, PA 17020 215-1709

SEWAGE ENFORCEMENT OFFICER/ZONING OFFICER
TBD
TBD

PLANNING COMMISSION
Arthur Dalla Piazza
306 Dellville Road, Duncannon, PA 17020 834-4228
Robin Bahrenburg
90 Aqueduct Road, Duncannon, PA 17020
Forrest Woodward
25 Allendar Drive, Duncannon, PA 17020 834-3003
Marsha Cavanagh
100 Sawmill Road, Duncannon, PA 17020 433-6274
Meranda Harwood
308 Dellville Road, Duncannon, PA 17020 856-0602

CONSTABLE
TBD

EMERGENCY MANAGEMENT COORDINATOR
Cory Stone
348 Newport Road, Duncannon, PA 17020 554-5547

RYE TOWNSHIP

BUILDING LOCATION ...1775 New Valley Road, Marysville, PA 17053
TOWNSHIP ADDRESS....1775 New Valley Road, Marysville, PA 17053
TELEPHONE 957-2348
FAX..... 957-9419
TOWNSHIP MEETING4th Tuesday, 7:00 p.m.
PLANNING COMMISSION MEETING..... 1st Tuesday, 7:30 p.m.
POPULATION2,263
MILEAGE.....26
E-MAIL ADDRESSryetwp@ptd.net
WEBSITE www.ryetwp.com

SUPERVISORS

Brad Sloop
3300 Valley Road, Marysville, PA 17053 957-2348
James Sabo, Chairman
121 Reed Drive, Marysville, PA 17053 957-2348
Sean M. Fedder
2985 Valley Road, Marysville, PA 17053 957-4602

SECRETARY/TREASURER

Daisy Lightner
1775 New Valley Road, Marysville, PA 17053 957-2348

TAX COLLECTOR

Rebecca Schulze
150 Lee Drive, Marysville, PA 17053 836-5692

AUDITORS

Cathleen Sabo, Chair
121 Reed Drive, Marysville, PA 17053 957-9458
Vickie Broughton
175 Stiles Drive, Marysville, PA 17053 877-2798
Deborah Lucas, Secretary
1044 Mountaintdale Drive, Marysville, PA 17053 957-3134

SOLICITOR

Dethlefs Pykosh & Murphy
2131 Market Street, Camp Hill, PA 17011 975-9446

TYRONE TOWNSHIP (continued)

ENGINEER

FSA, Matt Eck
P.O. Box 357, New Bloomfield, PA 17068 275-7531

SEWAGE ENFORCEMENT OFFICER

FSA, Leonard Sizer
P.O. Box 357, New Bloomfield, PA 17068 275-7531

PLANNING COMMISSION

Justin Morrett
1074 Sheaffers Valley Road, Landisburg, PA 17040 789-6272
Gary Frye, Secretary
675 Montour Road, Landisburg, PA 17040 789-3048
Michael C. Shaffer
335 Bridgeport Road, Landisburg, PA 17040 789-4377
Harvey Clouse
1451 McCabe Road, Landisburg, PA 17040 789-4220
James E. Lyons
2020 Landisburg Road, Landisburg, PA 17040 789-4114
Brett Bailey
714 Sheaffer's Valley Road, Landisburg, PA 17040 580-6984

ZONING HEARING BOARD

Aaron K. Morrison
924 McCabe Road, Landisburg, PA 17040
Corry D. Goodling
38 Raspberry Lane, Landisburg, PA 17040
Brian K. Campbell

ZONING OFFICER

FSA, Matt Eck
PO Box 357, New Bloomfield, PA 17068 275-7531

EMERGENCY MANAGEMENT COORDINATOR

Kyle A. Miller
35 Miller Lane, Landisburg, PA 17040 386-6915

TYRONE TOWNSHIP

BUILDING LOCATION. 3129 Shermans Valley Rd, Loysville, PA 17047
 TOWNSHIP ADDRESS..... PO Box 116, Landisburg, PA 17040
 TELEPHONE..... 386-3013
 TOWNSHIP MEETING..... 1st Tuesday, 7:00 p.m.
 PLANNING COMMISSION MEETING..... 3rd Tuesday, 7:00 p.m.
 POPULATION..... 1,905
 MILEAGE..... 22.18
 E-MAIL ADDRESS michael.shaffer73@yahoo.com

SUPERVISORS
 Edward D. Detter
 18 Beechnut Drive, Landisburg, PA 17040 275-2025
 Michael C. Shaffer
 335 Bridgeport Rd., Landisburg, PA 17040 386-3013
 Daniel J. Bolze
 3 Dempsey View Drive, Landisburg, PA 17040 226-5704

SECRETARY/TREASURER
 Michael C. Shaffer
 335 Bridgeport Rd., Landisburg, PA 17040 386-3013

TAX COLLECTOR
 Judy E. Zimmerman
 1988 Shermans Valley Road, Elliottsburg, PA 17024..... 991-2482

AUDITORS
 Pamela Brogan-Spacht
 209 Cornman Lane, Landisburg, PA 17040 789-3263
 Marlin C. Rice..... 460-6083
 Michael L. Irvine

SOLICITOR
 Dissinger & Dissinger
 400 South State Road, Marysville, PA 17053 957-3474

RYE TOWNSHIP (continued)

EMERGENCY MANAGEMENT COORDINATOR
 James Cassidy
 3430 Valley Road, Marysville, PA 17053 957-3566

SEWAGE ENFORCEMENT OFFICER
 FSA Engineering - Leonard Sizer
 15 E. Main Street, New Bloomfield, PA 17068 275-2048

PLANNING COMMISSION
 Thomas Graupensperger
 2220 Valley View Drive, Marysville, PA 17053 957-2576
 Gordon Warren
 P.O. Box 95, 2892 Valley Road, Marysville, PA 17053 957-3490
 Sean Fedder
 2985 Valley Road, Marysville, PA 17053 957-4602
 Camille Otto, Vice-Chair
 100 Reed Drive, Marysville, PA 17053 957-2933
 Daniel Vodzak, Chairman
 3 Reed Drive Marysville, PA 17053 957-2507

Ken Quigley
 2 Bellview Road, Marysville, PA 17053 315-5983
 Sue Crist
 1057 New Valley Road, Marysville, PA 17053 503-1147

ENGINEER
 Glace Associates, Inc.
 3705 Trindle Road, Camp Hill, PA 17011 731-1579

ZONING HEARING BOARD
 Stephen Smith
 2739 Valley Road, Marysville, PA 17053 462-5606
 John Fitzsimmons, PE, Vice-Chair
 135 Lambs Gap Road, Marysville, PA 17053 957-9380
 Anthony Leer
 910 New Valley Road, Marysville, PA 17053 648-8937

James Baker
 1178 New Valley Road, Marysville, PA 17053 545-7973
 John-Thomas Graupensperger, Chair
 2365 Valley Road, Marysville, PA 17053 576-7664

SAVILLE TOWNSHIP

BUILDING LOCATION 3954 Veterans Way, Elliottsburg, PA 17024
TOWNSHIP ADDRESS..... 3954 Veterans Way, Elliottsburg, PA 17024
TELEPHONE 438-3536
TOWNSHIP MEETING..... 1st Monday, 7:00 p.m.
PLANNING COMMISSION MEETING.....3rd Monday, 6:30 p.m.
POPULATION2,599
MILEAGE.....42.29
FOUNDED1817

SUPERVISORS

Mark McNaughton, Chairman
8608 Middle Ridge Road, Newport, PA 17074..... 275-4330
Grady Reisinger, Roadmaster
509 Fritz Road, Loysville, PA 17047 438-3168
Colton Beam, VP
402 Spriggle Hollow Road, Elliottsburg, PA 17024..... 636-3172

SECRETARY/TREASURER

Lori McNaughton
510 Erly Road, Elliottsburg, PA 17024 215-9413

TAX COLLECTOR - Elected

Karen Rush
448 Walllett Road, Ickesburg, PA 17037 438-3024

AUDITORS - Elected

Jodie Fuller, Secretary
1569 Liberty Valley Road, Ickesburg, PA 17037 438-3454
Carol Smith, Chairman
8658 Veterans Way, Ickesburg, PA 17037 438-3453
Jody Frey
1073 Liberty Valley Road, Ickesburg, PA 17037 580-6078

SEWER PAYMENTS

Trish Comp 275-4677

TUSCARORA TOWNSHIP (continued)

ENGINEER

John Madden, Madden Engineering 275-7531

SEWAGE ENFORCEMENT OFFICER

Wm Dan, Polly Graybill & Jeffrey St. John
25 Dolan Heights Road, Mifflintown, PA 17069 436-2291
Alternate SEO Lenny Sizer
24 N. 4th Street, Newport, PA 17074 275-2048

PLANNING COMMISSION

Rodney Zullinger, Chairman
4886 Raccoon Valley Road, Millerstown, PA 17062..... 589-7594
Patrick McIntyre
4144 Buckwheat Road, Millerstown, PA 17062 589-3143
Kerry Rehkamp
3972 Raccoon Valley Road, Millerstown, PA 17062..... 589-3948
Jeff Newlin
152 Mountainside Lane, Millerstown, PA 17062..... 438-3914

Jason Snyder

2714 Raccoon Valley Road, Millerstown, PA 17062..... 648-5115
Joe Haas

230 Haas Lane, Millerstown, PA 17062..... 525-0313
Sam Dienner

1568 Sugar Run Road, Millerstown, PA 17062 582-1843

ZONING HEARING BOARD

Bryan Kauffman
2835 Raccoon Valley Road, Millerstown, PA 17062
David Bratton
2633 Raccoon Valley Road, Millerstown, PA 17062
John D. Myers
24 Morning Star Lane, Millerstown, PA 17062
Justin Zullinger, Alternate
2661 Raccoon Valley Road, Millerstown, PA 17062

ZONING OFFICER

Debra Campbell
72 Cemetery Road, Millerstown, PA 17062..... 589-7911

CODE ENFORCEMENT OFFICER

Timothy Moench
86 Meadowgrove Road, Newport, PA 17074 441-5454

TUSCARORA TOWNSHIP

BUILDING LOCATION 72 Cemetery Road, Millerstown, PA 17062
TOWNSHIP ADDRESS ... 72 Cemetery Road, Millerstown, PA 17062
TELEPHONE 589-7911
TOWNSHIP MEETING 2nd Thursday, 7:00 p.m.
PLANNING COMMISSION MEETING..... 2nd Tuesday, 7:00 p.m.
POPULATION 1,308
MILEAGE..... 15.45
E-MAIL ADDRESS secretary@tuscaroratownship.com

SUPERVISORS

James Fuller, Vice-Chairperson
3337 Buckwheat Road, Millerstown, PA 17062 589-7807
Patrick McIntyre
4144 Buckwheat Road, Millerstown, PA 17062 589-3143
Wayne Campbell, Chairperson
1791 Shull Hill Road, Newport, PA 17074 275-5045

SECRETARY/TREASURER

Debra Campbell, Secretary/Treasurer
72 Cemetery Road, Millerstown, PA 17062 589-7911

TAX COLLECTION

Carol Moyer
390 Hominy Drive, Newport, PA 17074 567-6138

AUDITORS

Cathleen Smith
170 Creek Road, Millerstown, PA 17062 636-2597
James Deeny
108 Hominy Drive, Newport, PA 17074 567-3199
Larry F. Reisinger, Secretary
3006 Raccoon Valley Road, Millerstown, PA 17062 589-7258

SOLICITOR

Bruce Warshawsky
2320 N. 2nd Street, Harrisburg, PA 17110 260-3527

EMERGENCY MANAGEMENT COORDINATOR

Leonard Younth
5157 Raccoon Valley Road, Millerstown, PA 17062 589-0042

SAVILLE TOWNSHIP (continued)

SOLICITOR

Mark W. Allshouse, ESQ
15 Cove Road, Marysville, PA 17053 582-4006

SEWAGE ENFORCEMENT OFFICER

J.C. Smith
40 Old State Road, Shermans Dale, PA 17090 275-1222

PLANNING COMMISSION

John Sauder
Melvin Weaver
Lonnie Etter

ENGINEER - Vacant

EMERGENCY MANAGEMENT COORDINATOR - Vacant

SOUTHWEST MADISON TOWNSHIP

BUILDING LOCATION ...94 Bistline Bridge Rd., Loysville, PA 17047
TOWNSHIP ADDRESS...94 Bistline Bridge Rd., Loysville, PA 17047
TELEPHONE 536-3163
TOWNSHIP MEETING..... last Monday, 6:30 p.m.
POPULATION741
MILEAGE.....13.46

SUPERVISORS

Hugh McMillen
776 Andersonburg Road, Loysville, PA 17047 789-4192
Charles Adair
319 Shawnee Lane, Loysville, PA 17047 789-3540
Eugene B. Reisinger
1401 Couchtown Road, Loysville, PA 17047 275-6114

SECRETARY/TREASURER

Judy Campbell
6028 Shermans Valley Road, Loysville, PA 17047 579-0049

TAX COLLECTOR

Diane Bowman Shenk
285 Shenk Lane, Landisburg, PA 17040 582-1989

AUDITORS

Debra Smith
340 Andersonburg Road, Loysville, PA 17047 536-3633
Marsha Snyder
1140 Bernheisel Road, Loysville, PA 17047 536-0059
Wesley Smith
91 Andersonburg Road, Loysville, PA 17047 536-0073

SOLICITOR

William R. Bunt
P.O. Box 336, New Bloomfield, PA 17068 582-8195

TOBOYNE TOWNSHIP (continued)

SEWAGE ENFORCEMENT OFFICER

JC Smith
40 Old State Road, Shermans Dale, PA 17090..... 582-2043

PLANNING COMMISSION – PERRY COUNTY

CODE ENFORCEMENT

Thomas G. Bell, Sr.
300 Gainer Lane, Blain, PA 17006..... 414-6008

TOBOYNE TOWNSHIP

BUILDING LOCATION... 50 Lower Buck Ridge Road, Blain, PA 17071
 TOWNSHIP ADDRESS... 50 Lower Buck Ridge Road, Blain, PA 17071
 TELEPHONE 536-3154
 TOWNSHIP MEETING 1st Monday, 5:00 p.m. 423
 POPULATION 12.8
 MILEAGE..... 12.8

SUPERVISORS
 Dean W. Beaston, Chairman
 30 Lower Buck Ridge Road, Blain, PA 17006 536-3405
 Orle C. Beaston
 3230 Big Spring Road, Blain, PA 17006 536-3425
 Jeffrey W. Smith
 1250 Lower Buck Ridge Road, Blain, PA 17006 536-3126

SECRETARY/TREASURER
 Kimberly Reeder
 4007 Couchtown Road, Loysville, PA 17047 536-3154

TAX COLLECTOR
 Barbara Ann Herr
 5260 Fowler Hollow Road, Blain, PA 17006 536-9979

AUDITORS
 Quinn Howell
 Jodi Smith

SOLICITOR
 Salzman Hughes P.C.
 79 St. Paul Drive, Chambersburg, PA 17201

ENGINEER
 Pennoni Associates, Inc.
 704 Lisburn Road, Camp Hill, PA 17011 975-6481

SOUTHWEST MADISON TOWNSHIP (Continued)

SEWAGE ENFORCEMENT OFFICER
 Juniata Sewage Committee 436-9094

EMERGENCY MANAGEMENT COORDINATOR
 Wesley Smith
 91 Andersonburg Road, Loysville, PA 17047 536-0073

PLANNING COMMISSION - PERRY COUNTY

SPRING TOWNSHIP

BUILDING LOCATION 539 Paige Hill Rd, Landisburg, PA 17040
TOWNSHIP ADDRESS185 Richard Lane, Landisburg, PA 17040
TELEPHONE/FAX 789-4550
TOWNSHIP MEETING 1st Monday, 7:00 p.m.
PLANNING COMMISSION MEETING 4th Thursday, 7:00 p.m.
POPULATION 2,295
MILEAGE 42.10
EMAIL ADDRESS springtwp@embarqmail.com
WEBSITE springtwp.org

SUPERVISORS

David McLaughlin, Chairman
796 Germany Ridge Road, Elliottsburg, PA 17024 582-4847
Nathan J. Cleland, Vice-Chairman
10 Elk Lane, Shermans Dale, PA 17090 226-1050
Joshua Kirk
1134 Pisgah Road, Shermans Dale, PA 17090 713-0229

SECRETARY/TREASURER/ADMINISTRATIVE ASSISTANT

Wendy Campbell
69 Comp Road, Landisburg, PA 17040 215-0273

TAX COLLECTOR

Judy E. Zimmerman
1988 Shermans Valley Road, Elliottsburg, PA 17024 991-2482

AUDITORS

E. Kenneth Bair, II
1171 Landisburg Road, Landisburg, PA 17040
Duane Dietz
155 Greenbriar Road, Elliottsburg, PA 17024
Lee Ann McLaughlin
5 Clouser Hollow Road, Elliottsburg, PA 17024

SOLICITOR

Mark Allshouse, Esquire
15 Cove Road, Marysville, PA 17053 582-4006

SPRING TOWNSHIP (continued)

ZONING SOLICITOR

Alexis McConville, Dissinger & Dissinger
400 S State Road, Marysville, PA 17053 957-3474

SEWAGE ENFORCEMENT OFFICER/ZONING OFFICER

FSA - Leonard Sizer
15 East Main Street, New Bloomfield, PA 17068 275-7531

ENGINEER

FSA - Matt Eck
15 East Main Street, New Bloomfield, PA 17068 275-7531

PLANNING COMMISSION

Terry Meek, Chairman
187 Indiana Road, Landisburg, PA 17040 789-3548
John McElhiney, Vice-Chairman
1720 Landisburg Road, Landisburg, PA 17040 789-3126
Nick Columbus, Secretary
69 Comp Road, Landisburg, PA 17040 440-8890
Robert Bower
1055 Pisgah Road, Shermans Dale, PA 17090 582-7902
Jonette Zeigler
123 Pisgah Hill Road, Shermans Dale, PA 17090 580-6509

EMERGENCY MANAGEMENT COORDINATOR

Tereasa Hourtz
300 Flint Drive, Landisburg, PA 17040

ROADMASTER

Paul Trout
45 Comp Road, Landisburg, PA 17040 609-2900

ZONING HEARING BOARD

David Lucas
41 Pisgah Hill Road, Shermans Dale, PA 17090
Nemo Niemann
465 Kistler Road, Elliottsburg, PA 17024
Derek Hench
367 Germany Ridge Road, Elliottsburg, PA 17024